

Technology innovation and promotion in practice: pumps, channels, and wells

Reducing fuel consumption, emissions, and costs

Gert Jan Bom
Ibrahim Hafeez ur Rehman
David van Raalten
Rajeshwar Mishra
Frank van Steenbergen

PRACTICA

 Centre for the Development of Human Initiatives (CDHI)

 teri

 META
META

 The SMART Centre Group
Training the local private sector in Simple, Market based, Affordable and Repairable Technologies

© Tata Energy Research Institute

ISBN 81-7993-009-2

Material from this publication may be quoted with appropriate acknowledgement of the source.

Published by

TERI

Darbari Seth Block

Habitat Place

Lodhi Road

New Delhi – 110 003

India

Tel. 2468 2100 or 2468 2111

E-mail outreach@teri.res.in

Fax 2468 2144 or 2468 2145

Web www.teriin.org

India +91 • Delhi (0)11

Contents

<i>Preface</i>	<i>v</i>
<i>Acknowledgements</i>	<i>vii</i>
Introduction	1
CHAPTER 1 Pumps, wells, channels, and people	5
2 Diesel pump sets: beasts of burden	9
3 Manual pumps: the personal touch	23
4 Tube wells: springs of resistance	33
5 The stone hammer: in difficult territory	51
6 Conveyance: alternative routes	57
7 Dissemination: making it work	67
8 Rural marketing: making it sell	75
Index	89

Preface

There are today major concerns related to climate change and the impact of human activities on the environment ranging from the global to the very local level. There is need to find solutions to this set of complex problems, and the challenge lies in identifying those actions that help in solving global problems as well as those that affect the lives of every community directly at the local level. Answers will lie in a multiplicity of initiatives and actions, requiring innovations that are institutional, policy related and technological in nature.

It is in this regard that I am very happy to present this volume to its readers. It brings together the practical work done in improving the fuel efficiency of low-lift irrigation systems. This is not a marginal topic in India. There are 5–10 million diesel-operated tube wells in operation, almost all owned privately, in many cases by small farmers. The book discusses the various improvements to groundwater lift technology – the design of the pump set, the make-up of the well, the choice of the irrigation channel, as also the human system involved in this entire cycle – and the promotion and marketing of new fuel-efficient techniques.

The title of this publication, *Technology innovation and promotion in practice: pumps, channels and wells*, tells us that the human and technical systems add up or, rather, are extensions of each other.

What is of unique value is that this book is not ‘from the lab’, but comes ‘from the field’. Various time-tested interventions have been tried over the past five to eight years, starting in North Bengal in India. However, it is also important to present new innovations to familiarize others with the scope for fuel and emissions savings that are possible with a series of uncomplicated changes to a standard technology. Moreover, the improvements discussed in this book enable win–win situations and cost savings being achieved. This is a very powerful combination. It gives me all confidence that the different findings discussed in the book will result in wide application – in India and elsewhere – provided they are introduced on a significant scale.



R K Pachauri
Director-General, TERI

Acknowledgements

This book is so much the outcome of a collective effort that it is hard to distinguish who contributed what. Over a number of years we have worked on improving and promoting basic groundwater technology, every time excited by new openings and improvements. The cover of the book carries a few names, but there are many more of us.

Much of the ingenuity in detecting and developing various technological breakthroughs has come from various people working in the field. Generous and creative inputs were given by many, but very specially from Suresh Muregesu, D Konar, B K Mitra, T K De, S Pal, K K Chakraborty, B Majumdar, U Ghosh, P Some, P K Sen and P K Biswas. We want to mention Aris van Herwijnen here in particular – who did a lot of the work on the well filters and stone-hammer. In promoting the new technology Benu Kanta De, Subrata Majumdar, Dhananjoy Roy, of CDHI (Centre for the Development of Human Initiatives) and Guru Naik and Amithaba Sadangi of IDE (International Development Enterprises) have been exploring and breaking new grounds.

We also want to acknowledge the organizations that have had a very stimulating role in providing the critical mass in the process of promotion: pump manufacturers such as Bharat, BSA, Field Marshal and Kirloskar; the Agricultural Department and the Water Resources Investigation and

Development Department of the Government of West Bengal in persisting in including new technology in its packages; IDE in promoting the treadle pump in uncharted territory and finally and very much the *mistris* that have helped to reality-check the innovations. There are many but Bablu Roy and Gautam deserve special mention as well as the *mistri* cooperatives that now are promoting most of the new techniques.

The Royal Netherlands Embassy in New Delhi has been a source of assured support to the North Bengal Terai Development Project, under which much of the works was done. We in particular salute P S Rao of the Land and Water Section. Further, both ARCADIS Euroconsult and ICCO (India Canada Organization) have been of considerable help in supporting and promoting the new ideas beyond their remit. TERI, finally, has provided the conducive environment for putting the detailed work in a larger perspective. In this regard we would like to thank Dr Leena Srivastava, Director, Regulatory Studies and Governance division, TERI, New Delhi for her constant encouragement and support. A special word of thanks to Poonam Deveshwar, K P Eashwar, R K Joshi, R Ajith Kumar, T Radhakrishnan, and other text editing staff of the Publications Unit, for putting everything in final shape under great time pressure. Thanks are also extended to P K Jayanthan for indexing this book.

Introduction

Water is the single essential input required to sustain and increase agricultural productivity in India. The country receives about 1200 mm rainfall in an average year¹, yet rainfall throughout India is unevenly distributed and very seasonal in character. Hence, for part of the year, agriculture can only be sustained with irrigation. The agricultural landmass of India is enormous and is close to 39% of all arable land in Asia.

The ultimate potential for minor irrigation is of the order of 81.4 million ha of which 80% is from groundwater resources. Therefore, the groundwater-based schemes assume greater importance under irrigation sector, which is evident from the fact that 50% of the total irrigated area in the country is supported by groundwater resources (<http://www.nabard.org/roles/minor.htm>).

Of India's reassessed ultimate irrigation potential 43% is expected to come from groundwater. In fact in India, as elsewhere in the world, groundwater development has been the single driving force in agricultural development in recent years. This has been financed by farmers' investments, but also by substantial energy subsidies given by the government. Electricity subsidies to groundwater users in India are nominally estimated at 6–8 billion dollars yearly².

This is a staggering figure. It is almost twice the national outlays on surface irrigation and flood protection and more than ten times the public investment in water harvesting. Apart from the subsidized electricity tariffs, groundwater pumping is also supported through cheap diesel supplies.

A recent TERI study (Pachauri and Sridharan 1998) found that the highly subsidized supply of power and water has resulted in inappropriate utilization and, in several areas, overexploitation of water resources. Against a critical level of 85%, there are areas – for instance in Punjab and Haryana – where groundwater exploitation is way above annual recharge levels (TERI 2001). On the other hand, particularly in the east of the country, there is a large area where groundwater is hardly used in spite of substantial opportunities. The study establishes the general sorry state of water management in the country. There is massive waste of water used for surface irrigation. Moreover, inefficient utilization of irrigation water, distortion of drainage paths and neglect of drainage have also resulted in waterlogging and salinity (TERI 2001). According to the estimates of the Ministry of Water Resources, Government of India, during 1990/91, not less than 2.5 million hectares under different irrigated command areas suffered waterlogging and

¹ <http://krishiworld.com>

² More in-depth analysis suggests that a substantial part of these enormous power subsidies, probably close to 50%, may in fact cover transmission and distribution losses booked under agricultural flat rates (Ranganathan 1998 quoted in Jurrius 2000).

about 3.3 million hectares were affected by salinity or alkalinity (Planning Commission 1999). In the coming years, the social, economic, and ecological productivity of water control systems will have to improve considerably—not only increase the efficiency of water use to meet the growing demand, but also to release water for other uses (Pachauri and Sridharan 1998).

In the agricultural sector, animate energy (human and draught power) accounts for more than one-third of the total energy consumed. Inanimate energy inputs are mainly in irrigation through diesel and electrical pump sets. The latest estimate of pump sets in the country by the Central Ground Water Board is about 19.5 million. Of this number 11.5 million pump sets have been energized and 8.0 million are operated with diesel prime movers. It appears that in recent years the increase in number of electric tube wells has tapered off, whereas the number of diesel pumps continues to grow.

The reason for the stagnation in electric pump sets are the overall power shortages, due to which supply to agriculture users is heavily rationed. There is a long waiting period (often as long as 3–5 years) for farmers to get an electricity connection. Moreover, the three-phase power supply to the agriculture sector is typically rostered amongst the various feeders for a specified number of hours every day. The three-phase supply during the scheduled timings of the roster is referred to as the ‘scheduled supply’. The actual availability of three-phase supply to farmers differs from the scheduled supply on two accounts. First, there are frequent power cuts during the scheduled hours of supply (due to transformer burnout or otherwise). Second, it is also common for power to be available outside

the scheduled hours. The overall unreliability and the hassle creates an uncertainty that does not go well with cultivating crops that are sensitive to the timing of irrigation (such as vegetables and high yielding varieties of wheat) (<http://www.usaid.gov>).

Given the poor availability, coverage, and reliability of electricity supply, diesel pumps have become more and more the preferred option, particularly in areas where water tables are shallow. In addition, in areas where surface canals are the main source of irrigation and groundwater is used conjunctively, farmers prefer to use diesel pumps rather than electric pumps. The reason is that for electric pumps they have to pay a fixed tariff irrespective of use, whereas for a diesel pump they pay per unit of diesel consumption. A diesel pump is hence more profitable at low levels of consumption. One estimate is that of the total diesel consumption in the country 26% now goes to farmers. According to a study by Powerline Research, captive power is now estimated at 20 000 MW or 22% of India’s power production. Cheap diesel makes captive power cheaper than power from the state electricity boards.

However, a large number of both diesel and electric pump sets are of sub-standard quality and operate at sub-optimal efficiency. Often the pumps have wrong features, e.g., high discharge head, inefficient foot-valves, pipes with excessive friction, oversized motors, and motors without capacitors. In addition, there are substantial energy losses, because of very high friction losses in wells or inefficient conveyance systems. It is estimated that the country could save 57 billion kWh of electricity and substantial quantities of diesel if higher

efficiency is achieved in the agricultural pumping sector.

This makes the topic of this book of more than passing interest. Improving efficiency in pumps and wells, channels and people can mean substantial savings in private and public expenditures. Whereas in the subsidized flat rate environment of electric pump sets, farmers have little incentive to save on power consumption, leaving it all to the state electricity boards, in diesel-operated pump sets, energy saving immediately translates in reduced costs to farmers. The scope of these energy efficiency improvements – as discussed in the remainder of this book – is moreover substantial—more than 50%, as confirmed by other research as well (TERI 1981). Obviously there is still a long way to go but we hope that this publication helps in getting things going in the right direction.

References

Jurrius I. 2000

Energy conservation in pumping water for irrigation in India

University of Utrecht: Department of Science, Technology and Society.

Pachauri R K and Sridharan P V (eds). 1998
Looking Back to Think Ahead: GREEN India 2047

New Delhi: Tata Energy Research Institute. 346 pp.

Planning Commission. 1999

Thematic issues and sectoral programmes Ninth Five Year Plan 1997–2002, vol. 2

New Delhi: Planning Commission, 1059 pp.

Ranganathan V. 1998

Impact of pump set energization on the power sector

In *Proceedings of the seminar on Agricultural pumping: emerging dimensions and impact on the power sector.*

Bangalore: Central Board of Irrigation and Power.

TERI. 1981

Study on the conservation of light diesel oil and electricity used in pump sets for lift irrigation in Gujarat state

New Delhi: TERI

TERI. 2001

Directions, Innovations, and Strategies for Harnessing Action for sustainable development

New Delhi: TERI 368 pp.

Pumps, wells, channels, and people

‘If the improvements are so obvious, why have they not come about?’

With farmer-operated low-lift irrigation taking care of a very substantial portion of agricultural water requirements in major agricultural economies, it is amazing that little study has gone into the technology underlying it. We hope that this small book contributes to narrowing that gap. It discusses improvements in manually operated and diesel-operated pump sets, well technology and water conveyance, and ways of promoting and introducing changes.

The material in this book is culled from six years of extensive trials, participatory technology development, and promotion in an area of north-east India that, for many, holds the promise of considerable agricultural growth. The *World Water Vision* (Cosgrove and Rijsberman 2000) estimates that to keep up with food demand the world's area under irrigation has to grow by 17% over the next 25 years, even if considerable gains in the efficiency of agricultural production are assumed. Yet, there is at the same time a pervasive global water crisis—manifest in overused rivers and aquifers, deteriorating water quality, and threats to aquatic ecosystems. With ‘water security’ thus caught between a stone and a hard rock, the vast Terai groundwater belt that stretches south of the Himalayan range offers a fortunate exception. The plains bordering the mountains and foothills are marked by relatively coarse alluvial soils

and high rainfall, resulting in generous recharge and an abundant supply of groundwater at shallow depths. The number of shallow tube wells has grown rapidly over the last few decades. Initially, electric pump sets were the preferred prime movers, but with decreasing reliability and increasing costs of power, diesel pump sets have taken over.

In the three districts where the research for this book was undertaken – Darjeeling, Jalpaiguri, and Cooch Behar in northern West Bengal – the number of shallow tube wells has more than doubled in the last decade. In addition, manual lift irrigation systems are providing livelihood security to a vast number of people who do not have access to water otherwise.

The low-lift farmer-operated irrigation technology that this book discusses however, is also common in several other water environments. We hope, for instance, that the findings are relevant to areas under conjunctive water use (as in the Indus Basin), lift irrigation from canals (the Nile Delta, for example), small-scale river lift systems (as in Africa) or groundwater irrigation (in China).

The main message of this text is that technology development is essentially a social process. We consider it a pity that while the engineering and social science disciplines have developed their own vantage points and priorities, their interface is still

so undeveloped. It is, for instance, hard to deny that technological development is one of the strongest forces driving social change. Pump, well, and channel technology have a strong relationship with ownership and access to water. The right choice of technology promotes social objectives and can provide small farmers with access to water through individual or group ownership or through rental markets of water equipment. Some examples of individually owned manual pump technologies are the bucket pump, the hand pump, and the treadle pump. They are all strongly self-selecting, because they are particularly useful on farms, where families have the labour to operate them. Treadle pumps being very portable have also been purchased by landless farmers, who use them on rented land. The promotion of treadle pumps in combination with low-cost bamboo wells then gives poor farm families the opportunity of owning a well although the extremely poor may still not be able to, with the risk and investments of irrigated agriculture well beyond their means.

Another example of the relationship between ownership and technology is seen in pump-operated shallow tube wells. Shallow tube wells are for the relatively rich, because of their nature. They can irrigate medium-sized holdings (3 hectares and more) and the investment costs are relatively high (in the study area, 500 dollars). As Shah (1993) has documented, non-owners will still be able to irrigate by hiring pumping equipment. However, where the density of pump sets is low, this rental market (sometimes called a 'water market') is a sellers market and non-owners either pay dearly or have no access to water. To counter this trend there have been public

programmes that promote group ownership. The study area is no exception to this trend, but, as elsewhere in group pump set programmes, people are gravitating towards single ownership, particularly in one-well-one-pump set schemes. Often the owner of the land on which the well is situated becomes de facto the only user. Intriguingly, this trend toward single-person ownership has, at times, been reinforced by participatory approaches. This happened where farmers had to share in the capital costs, but insufficient time was given to collect the contribution. Typically, one resourceful person would make the obligatory contribution, avail of the opportunity, and have the well set-up on his land. A change in technology managed to counter this trend. Rather than having a single pump set and a single well, each small landowner was asked to develop a well on his/her own land. For this he/she could use any technology he/she liked—inexpensive bamboo wells, PVC (polyvinyl chloride) pipes, or more expensive (but not necessarily more effective – *see* Chapter 4) brass filters or galvanized iron wells. This freedom of choice enabled every group member to have a well of his/her own. Subsequently, a lightweight pump set was procured (*see* Chapter 2), which could easily circulate between the different off-take points, being easy to carry. As a result, the shared ownership in such, so-called, 'multi-filter point' shallow tube wells was much higher, not because of strong group development but because the choice of technology made pump sharing possible. Moreover, the lightweight pump sets were far easier to rent out. Several of these group pump sets were owned by women's groups, empowering them with assets and resources (Figure 1).



Figure 1 Sisters in arms

Appreciating technology development as a social process is also important in understanding why some inventions become popular and others do not. There is sometimes an almost Darwinian tendency to think that ‘the best will take care of itself’ and that a superior and appropriate technology will disseminate on its own strength. However, the work in the Terai areas of northern West Bengal suggests otherwise. First, it is difficult to define what

‘appropriate’ is. There are several examples in this book of how factors, such as convenience and safety were shown, the hard way, to be as important as technical performance (Box 1). The low popularity of drum cooling on pump sets (creating a fear that the pump set would burnout) or the heavy-duty treadle pumps (which were not portable, however) underlines this point. However, even when the right balance is found technological improvements do not spread automatically or effortlessly. There were, for instance, major gains to be made in fuel efficiency and ease of use in diesel pump sets, yet modifications were only slowly adopted. Similarly, there are several reasons why less efficient pump sets continue to be popular—manufacturers do not necessarily have the capacity to undertake research and development, so classic models still abound in the small-scale pump industry. Moreover, feedback from the users is poor because pump sets are assembled elsewhere and the dealers do not

Box 1 Wrong choices

Under the World Bank Minor Irrigation Project approximately 1000 electrically operated shallow tube wells were to be developed in northern West Bengal by 1993. The shallow tube wells were to be group-owned, each group consisting of 4–6 farmers. The tube wells were developed in clusters of six (among others to save on the expenditures of providing power lines) and as a cluster they were to be managed by a joint committee under the block-level *Panchayat Samiti*. Though one may question the institutional concept (such as the lack of ownership by farmers and the use of cluster committees), it was in the choice of technology that much of the misery of the project was rooted. First electric tube wells take a notoriously long lead-time to develop, as the different components – drilling, construction, and power supply – tend to be handled separately. At the end of the project only 15% of the shallow tube wells were in operation. Moreover, the technology had severe constraints. Farmers became slaves to the erratic power supply. Water trading was not possible because the pumps were fixed at a single place and the discharge was too small to be carried over a large area. All of this was achieved at a high cost—the cost of an electric connection to a tube well is several times the cost of diesel as a prime mover.

report back. Conservatism is further entrenched in official specifications, the dealer's product ranges, and a farmer's preferences. Similarly, the promotion of the treadle pump, a superior manual irrigation technology, was slowed down by the limited selling capacity of undercapitalized dealers (*see* chapter 8). Introducing better low-lift technologies requires the use of a spectrum of interventions—from familiarizing mechanics to changing specifications, so as to alert manufacturers (*see* chapter 7). In this respect, it is unfortunate that in large and potentially trendsetting procurements, wrong choices continue to be made blindly.

In this book the different components of low-lift groundwater technology are discussed. Mechanical and manual pumps are discussed in chapters 2 and 3, respectively, while wells and conveyance systems are discussed in chapters 4 and 6, respectively. Chapter 5 is a small detour into drilling techniques in problem areas, such as those with hard soil layers. The chapters aim to document the often considerable improvements – from the socio-technical perspec-

tive – in prevalent technology. Collectively, they are a plea to not to accept the status quo but to continue to invest time in improving even conventional technology.

Chapters 7 and 8 discuss the promotion of groundwater technologies. Chapter 7 describes the efforts, successes, and failures, in introducing a more appropriate technology. Chapter 8 focuses particularly on using the private service sector in this area.

We hope this set-up speaks of a balance between the two dimensions: low-lift technology and the water-related social economy. The chapters have been written so that they can be read independently.

References

- Cosgrove W J and Rijsberman F R. 2000. *World Water Vision: Making Water Everybody's Business*. London: Earthscan and World Water Council.
- Shah T. 1993 *Groundwater markets and irrigation development: political economy and practical policy* Oxford/Delhi: Oxford University Press

Diesel pump sets: beasts of burden

The importance of saving fuel

There are millions of diesel pumps operating in South Asia, with India alone accounting for an estimated 6–7 million units. Besides the diesel pump sets, there is an even larger number of electric irrigation pump sets, operating usually in areas with deep water tables. Some areas with shallow water tables such as Punjab (Pakistan) and Bihar (India), shifted from the use of electric prime movers to diesel prime movers in the 1990s, in response to the hidden cost of an unreliable power supply and cumbersome billing procedures.

Farmer's groundwater technology as a whole is glossed over as a topic for research or commercial research and development. One can speculate about the reasons. It appears that all research has gone into surface irrigation, where the big public investments take place. In the pump business sector in South Asia there has been a tradition of importing technology, related probably to an insensitive market with small margins, influenced at best by approved specifications, but not by measured output.

Surprisingly little research has gone into the efficiency of these 'flywheels of the green revolution'. The major exception is a series of studies initiated out of concern for the high and unsustainable levels of subsidized agricultural electricity supply. In India the total agricultural subsidy amounts to 5.6 billion dollars, equivalent

to the loss of the state electricity boards and easily surpassing the national budget for a small country. Elsewhere, the on-going privatization of power supply and distribution is eroding the financial base for a subsidized agricultural supply. Studies have established that savings in electricity consumption up to 30% are possible. These can be achieved largely by using improved foot valves, check valves, and by matching the pump and prime mover better (Patel 1988).

Whatever limited research on efficiency improvement has been conducted has gone into these electric pump sets. There is relatively little work on the efficiency of diesel pump sets even though the current volatility of oil prices has raised the *de facto* subsidy on diesel, making the relevance of such research urgent.

The next sections describe how it became possible to achieve savings of 50% in diesel pump sets in the Terai plains. For a country like India national savings of 1.3 billion litres of diesel is possible annually, which would mean a 15% reduction in the import of high-speed diesel.

Improving existing diesel pump sets

The diesel pump sets used in India can be classified into two main categories. One category is surface-operated pumps in which the pump and engine are both at ground level, drawing the water up from a

maximum depth of 8 m, by suction. The other category is deep-set pumps where the engine is at ground level but the pump is installed in a pit, closer to the water level. These can be used for water levels about 15 m below the ground, beyond which electric pump sets are more attractive.

Surface pumps are usually models with a direct-coupled centrifugal pump, the so-called Petter type. Recently mono-block type pumps have also come into the market. In some areas – in particular where deep-set pumps are necessary– the slow speed (6–10 hp [horsepower] at 600–1000 RPM [revolutions per minute]) Lister-type engines are also popular, which drive a separate pump through a flat-belt transmission.

In the Terai plains, shallow groundwater tables prevail. Surface diesel pumps are used for irrigation and the Petter 5 hp/1500 RPM model (Figure 1) is ubiquitous. This particular pump was studied in detail and it became apparent that its fuel efficiency was quite low. At a total head of 6 metres, such a pump would typically have a discharge of only 10 litres/second, with a fuel consumption of one litre per hour. A number of modifications were attempted and their impact measured. Some turned out to have only a marginal effect on fuel efficiency, while others had a strong impact. After modification, the same discharge was maintained with a fuel consumption of only 0.5 litres/hour – a 50% saving! The most effective modifications were

- removal of the foot valve or check valve,
- reduction of the engine speed, and
- increase in the cooling water temperature.

The testing went through a process of trial and error. The process consisted of basically three phases. The first phase con-



Figure 1 Typical 5 hp/1500 RPM diesel pump, before modification

sisted of the introduction of each modification successively. The drum cooling was introduced, subsequently the valves on the already modified engine with new cooling, and then the speed control.

In the tests the lower discharge caused by the decrease in speed was compensated by the increase in flow due to the removal of the foot valve/check valve. The total savings in fuel consumption were 51% for shallow tube wells and 57% for the pump-dug wells (Figures 2 and 3).

In the second phase, the modified pump set was run for 600 hours to test for long-term negative effects.

Finally, 11 pump sets owned by farmers were modified and then operated for one week (during the irrigation off-season).

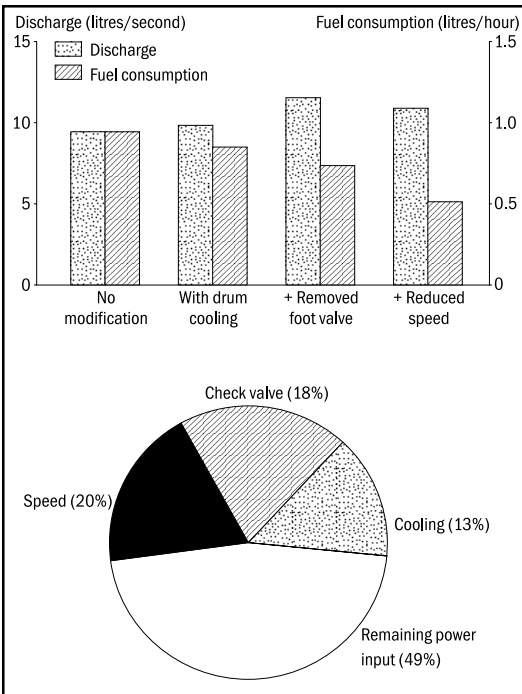

Figure 2 Fuel consumption versus discharge for each modification on a shallow tube well, at a static head of 3.5 m and the contribution of each modification to the total fuel saving

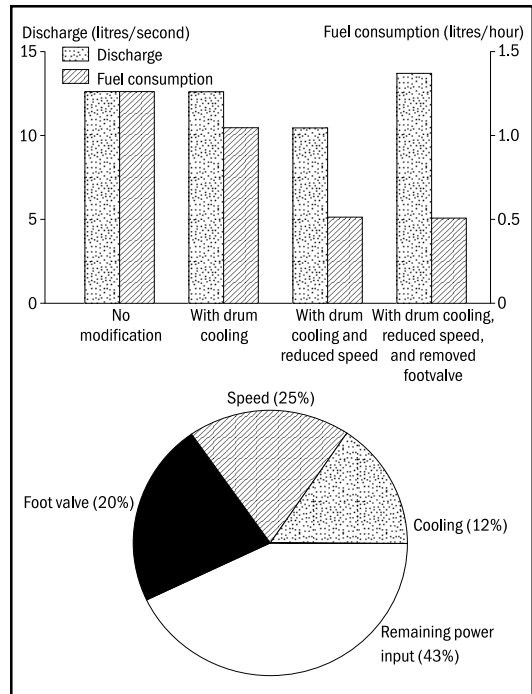

Figure 3 Fuel consumption versus discharge for each modification on a pump dug well, at a static head of 4.5 m and the contribution of each modification to the total fuel saving

This field experiment reconfirmed that fuel savings were between 45% and 60% and farmers had no difficulties operating the modified pump sets.

The impact of each modification is described below.

Removal of check valve/ foot valve

Shallow tube wells have a check valve fitted between the well and the pump set (Figure 4). This valve is required to keep water in when the pump is being primed and to start the pump set. When the check

valve and nozzle were removed, (*see* Box 1) the friction losses at the delivery side reduced from 6.5 m to 4 m, a reduction of



Figure 4 The high-friction check valve as used on shallow tube wells

Box 1 But it looks better. . .

Farmers hesitated to remove the nozzle at the end of the delivery bend. Although in most cases it served no purpose at all, the farmers thought that it delivered much more water while actually, it only increased the velocity of water emerging. In fact, a nozzle will reduce the discharge, but when the neighbours are watching, water emerging at a higher velocity is distinctly more impressive.

nearly 40% (Figure 5). The remaining 4 metres are largely due to filter losses, a subject that was also studied and is described in chapter 4.

Pumps fitted on open dug wells have a foot valve, instead of a check valve. The

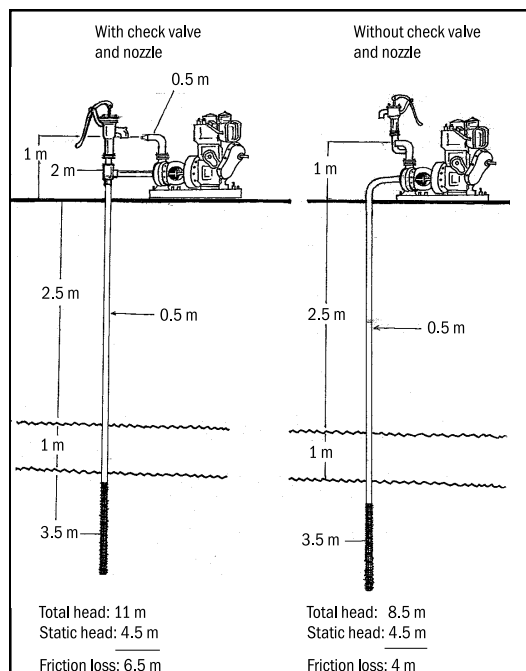

Figure 5 Friction losses for shallow tube wells with and without check valve and nozzle

foot valve also allows the pump to be primed by filling water from the discharge end (Figure 6). Experiments showed that friction in the foot valve imposed an extra 2.6 m of suction head on the pump. Moreover, many foot valves did not work smoothly at all, creating even higher losses. The removal of the valve together plus the nozzle reduced the friction losses from 3.6 m to 0.5 m (Figure 7).



Figure 6 The high-friction foot valve as used on dug wells or pumping from surface water

However, since both valves are required for priming, an alternative had to be provided. A hand pump was mounted on the discharge side to be used for priming and starting the pumps.

It is worth mentioning here that the nozzle was found to create an additional head equal to half a metre. This may not seem much but at a water depth of 2 m only, a half-metre means 20% extra head and, hence, roughly 20% less water for the same fuel consumption. There is however also a cultural aspect to the presence of this nozzle (Box 1).

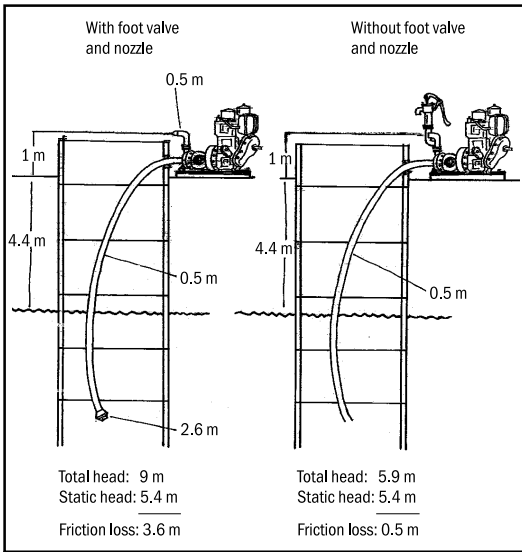

Figure 7 Friction losses for pump sets on open dug wells, before and after removing the foot valve and nozzle

Reduction of engine and pump speed
Engine speed

A diesel engine operates at optimum fuel efficiency if it runs at a high load factor. This means that the horsepower actually delivered is close to the engine’s potential at the given speed. An analogy: one does not need a very heavy truck to transport cotton, a light material, or a very big bus to carry only one person. For typical operating conditions in the Terai plains, the power required for 5 hp diesel pump sets hardly ever exceeds 2 hp. Consequently, the load factor is often not more than 40%. With a reduction in engine speed from 1500 RPM to 1000 RPM, the load factor improves to 60%. Figure 8 shows the typical relation between engine speed, horsepower, load factor, and fuel efficiency. It follows from these diagrams that, theoretically, the fuel efficiency can be improved even further by

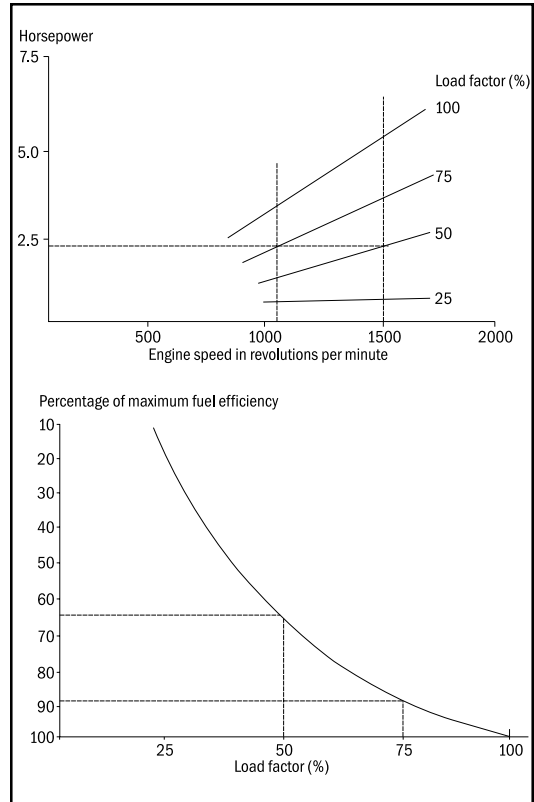

Figure 8 Relationship between engine speed, horsepower, load factor, and fuel efficiency

lowering the speed more. However, this did not prove practically possible, probably due to the design of the fuel pump plunger (Figure 9).

An additional advantage of reduced engine speed is a proportionate reduction in the wear of the engine since wear is related to the accumulated rotations rather than operating hours. This implies that the service life of the engine may be extended by about 30% due to the 30% decrease in speed. An engine, which would normally last 8 years, may now be expected to last 10 years. Interestingly enough, this argument

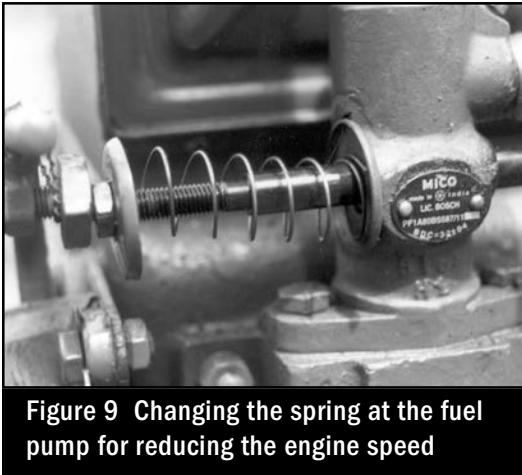

Figure 9 Changing the spring at the fuel pump for reducing the engine speed

matches the general consensus in India that low-speed engines last longer than high-speed engines.

Another additional advantage was observed in the field. The interval between oil changes of the engine has increased from 60 to 90 hours. Oil change takes place when the farmer, after rubbing some oil between his fingers, considers that lubricating properties are not sufficient any more. However, even 90 hours is rather low. 200 hours is the norm for good oil in a good engine. Given that oil costs \$ 2 per litre and that 3.5 litres are required per oil change, each change costs \$ 7. This means a running cost of \$ 0.12 per hour for 60 hours, which is reduced to \$ 0.08 in modified pump sets.

There could be two possible explanations for oil lasting longer in a modified pump set. First, the reduced speed means a reduction in the number of combustions and at each combustion, the oil is degraded because soot and aggressive gases mix with

it. Second, a higher engine temperature means a better fit between the piston and cylinder (the piston being of aluminium with a much higher heat expansion than the steel liner), which reduces the leakage of harmful substances along the piston and extends the oil's life.

Pump speed

Pumps, which are commonly used with 5 hp engines, have a duty point (best efficiency) at 16 litres per second and 16 m total head (suction, friction, velocity, and delivery). Since the engine and pump are coupled directly, a reduction in engine speed means an equal reduction in pump speed.

The actual discharge in the field was between 10–12 litres/second, with a total head of not more than 8 m. So, these pumps operate at an efficiency much lower than optimum. The best efficiency these pumps can attain is 75% but at a discharge of 10 litres/second it is reduced to about 58%. However, a reduction in speed at the same rate of discharge, actually improves the efficiency because the reduced discharge from the duty point (10 litres/second instead of 16 litres/second) is then matched by a proportional reduction in the peripheral velocity of the impellor (1000 RPM instead of 1500 RPM). This reduced speed further reduces friction losses in the pump.¹ Out of a total fuel efficiency improvement of 25% brought about by speed reduction some part is due to the engine operating at a higher load factor and some because of improved pump efficiency (Figure 10).

¹ The reduced speed improves the matching of the relative water velocity angle at entrance and exit of the impellor with the actual angle of the impellor vanes and thus the friction losses are further reduced.

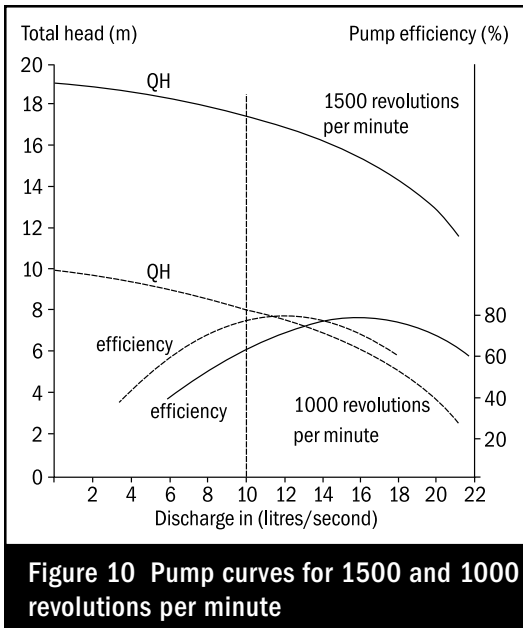

Change in cooling system

The present practice in the Terai plains is to cool the engines of irrigation pumps by passing some of the pumped water through the engine head and cylinder jacket, the so-called run-through system. Given the high flow rate of water-cooling, its low temperature, and the actual heat generated by the engines, there is excess cooling with the engine temperature remaining around 30 °C instead of the prescribed 80 °C. Farmers seem to hold the view that if cooling is good, more cooling must be better.

This low operating temperature increases fuel consumption by (1) increased thermal losses and (2) increased gas leakage past the piston rings. It may also lead to carbon deposits on the cylinder head, valves, and injector nozzle, necessitating more frequent cleaning.

There are two methods of increasing the engine operating temperature. One is by

reducing the cooling water flow to a point where the desired temperature is reached. The alternative is introducing a thermo-siphon drum cooling system. At first it was thought that drum cooling was the better choice because of complications in restricting the flow, in particular the danger of a blockage because of dirt. So, drum cooling was promoted in the modification package. This worked all right technically. Several hundred pumps were modified and a fuel saving of about 50% was achieved. However, farmers complained about the awkwardness of the cooling drum, filled with steaming water. They were concerned that the high water temperature might damage the engine. This required them to be more vigilant, which they did not require in refilling the drum, when the pump was in operation. Since drum cooling appeared to be hindering acceptance by the farmers of the fuel-saving modified pumps, it was abandoned in the modification package for shallow tube wells.

Drum cooling is still preferred in some cases for river water lifting because the water pumped from the rivers contains quite a lot of silt. With a run-through cooling system, this silt tends to settle in the engine jacket and after a certain amount of accumulation, the cooling of the cylinder becomes insufficient, causing damage to the engine. In that case the closed drum cooling system is a better option.

In the case of run-through cooling the necessary pressure is created by inserting a 'half pipe' (a half-inch [1.5-cm]) piece of pipe with a scoop-like extension) into the body of the pump (Figure 11). This creates sufficient pressure without affecting the discharge as the nozzle did, which farmers would screw onto the discharge bend.



Figure 11 Half-pipe for creating cooling water flow pressure

Economics and farmers acceptance

It is one thing to develop technical improvements but if they require hefty investments, they are not likely to have much impact. The modifications as presented in this chapter are fortunately neither costly nor complicated. The average cost of modifying a PDW (pump dug wells) for 50% fuel saving is Rs 400 (\$ 8.70) and for STW (shallow tube wells) Rs 150 (\$ 3.26). The PDW pump sets are more expensive to modify because a hand pump for priming must be purchased, while the STW already has a hand pump.

With diesel costing Rs 20/litre and a 50% saving, the pay-back time for modifying a

PDW is 40 hours and for an STW only 15 hours of operation. Assuming that these pumps run an average of 500 hours per year, the farmer will save Rs 5000 (\$108) annually after modification. From that perspective, the investment is really negligible. The small investment required and simplicity of the modifications should make it possible to introduce these modifications on a large scale through promotions only, i.e., subsidies will not be required. The approach taken and lessons learnt are described in chapter 7, which discusses dissemination strategies. Box 2 presents the conclusion on the diesel pump set modifications.

Box 2 Conclusions on diesel pump set modifications

- Introducing some minor modifications as used in the Terai plains can double the fuel efficiency of the diesel pump sets
- Most important modifications are removal of check or foot valve, reduction in engine speed, and reduced cooling
- The currently used 5 hp pump sets in the Terai plains are oversized, 2.5 hp pumps works as well or better (see next section).

Improved new diesel pumps

Every year thousands of new diesel pumps are sold in the Terai plains and while modification is an option, it would be better to improve the design of new pump sets in order to make modifications superfluous. Considering the actual maximum hp (horse power) requirement, well capacities, and static water levels, it is obvious that the present 5 hp pump set is oversized. A suitable diesel pump is produced by BSA

in Agra, which needed only minor adaptations to fit the requirements. The adaptations required were as follows.

- Reduction of power from 3.5 to 2.5 hp by reducing the speed from 1500 to 1000 RPM
- Design of a new pump impellor and volute casing to suit the duty point at 1000 RPM
- Providing the pump with a horizontal discharge spout to obviate the need for a bend
- Providing a 1.5 inch threaded connection on the pump housing for fixing the priming pump.

This was done and a first prototype was satisfactorily tested for 600 hours. The improved diesel pump and the currently used 5 hp pump set (Figure 12) are compared in Table 1.

The improved pump set has a better fuel efficiency than the present pump set modified because the former's duty point is closer to the actual working point. Another



Figure 12 The improved 2.5 hp pump set next to a common 5 hp pump set

important advantage is its low weight (less than half of the original pump set's). The low weight makes it easier to carry around and share. With the existing 5 hp pump sets weighing 220 kg, this is difficult. The existing pump sets, because they are so heavy, are moved as little as possible, and as a consequence, the water has to be conveyed from a single well to the outermost reaches of the command area. This means relatively long channels and consequent water loss.

Table 1 Comparison between the improved and present pump sets

Item	<i>Improved pump set</i>	<i>Present pump set</i>
Engine	Diesel 2.5 hp ^a at 1000 RPM ^b Flow restrictor run-through cooling Speed set at 1000 RPM	Diesel 5 hp at 1500 RPM Free run-through cooling Speed set at 1500 RPM
Pump	Duty point: 12 litre/second at 7-m head 1000 RPM Horizontal discharge 3 inch × 2.5 inch connections	Duty point: 16 litre/second at 16-m head 1500 RPM Vertical discharge 3 inch × 2.5 inch connections
Weight of complete pump set	105 kg	220 kg
Configuration	Mono-block	Separate pump and engine on base frame

^a Horsepower; ^b revolutions per minute

This in turn, means reduced fuel efficiency because longer pumping times are required. A lightweight pump set on the other hand, can easily be moved to another well, reducing the distance and saving fuel. It has been observed that apart from saving fuel, the effective command area of a lightweight pump used on multiple wells is more than with conventional heavy pump sets.

Apart from selling water to neighbouring farms, pump sets are also rented out. Given the weight of the existing pump sets, this renting out is only feasible if the pump set will work for certain minimum time (reportedly at least four hours), otherwise, the cost of hiring labour to move the pump set is higher than the benefit received. The introduction of a lightweight pump set is expected to lower this threshold so that farmers with less land will be able to rent pump sets more easily.

For the moment the improved 2.5 hp pump sets are only slightly cheaper than the 5 hp pumps. This hampers their acceptance because farmers question the logic of purchasing a 2.5 hp pump for the price of a 5 hp pump.

However, this is an erroneous impression because horsepower should not be



Figure 13 Moving a 5-hp pump set



Figure 14 Moving a 2.5-hp pump set

equated with performance. The 5 hp pump set, even when modified, has a lower discharge than the new 2.5 hp pump set. If more manufacturers start making the mono-block 2.5 hp pump set, increased competition will reduce the price.

Box 3 Conclusions on the new design of the 2.5 hp pump set

- The newly developed 2.5 hp pump set is well received by the users because of its low fuel consumption, good discharge and especially its low weight.
- The cost is still the same as for 5 hp pump sets. If other manufacturers take up the same design, the price will go down.

Possible impact on national level

National setting

The previous sections described how 50% savings became possible for diesel pump

sets in the Terai plains. The next question was, what will be the possible impact on national level? To answer that a rapid survey was carried out and existing literature searched to understand the applicability of these modifications on a larger scale.

At present, the number of small (3.5 to 10 hp) diesel pump sets is estimated to be at least 6.5 million. These are roughly divisible into two equal categories.

- 1 Three million shallow pump sets where the water table is less than 9 metres deep. The pumps are either direct coupled or belt driven and the engine and pump are placed at ground level (Figure 15).
- 2 Three million deep-set pump sets where the water table is deeper than 9 metres. In this case the engine rests on the sur-

face and the pump is installed lower down in a dug well or pit. The transmission of the power from the engine to the pump is usually through a long flat belt and pulleys (Figure 16).

There are, broadly speaking, two types of engines used, to drive both shallow and deep-set pumps, as indicated in Box 4.

Potential saving

It has been demonstrated in the Terai plains that the modifications to high-speed diesel pump sets result in an average fuel saving of 50%. The rapid survey of pump sets in other parts of India led to the following estimates of fuel-saving potential.

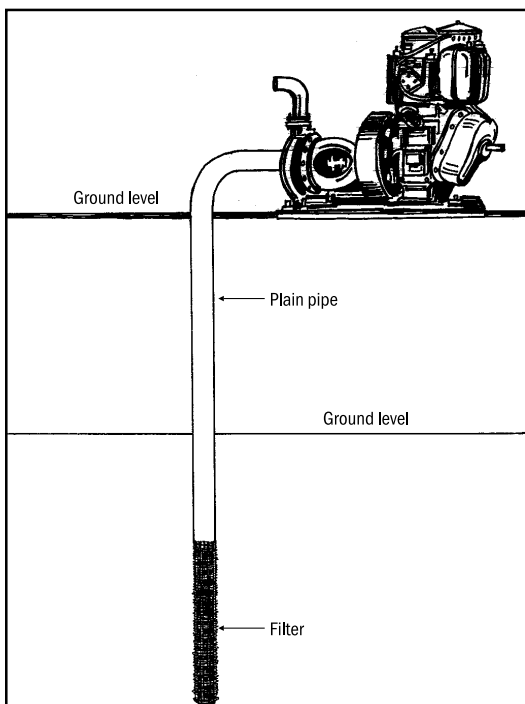

Figure 15 Typical shallow tube well arrangement

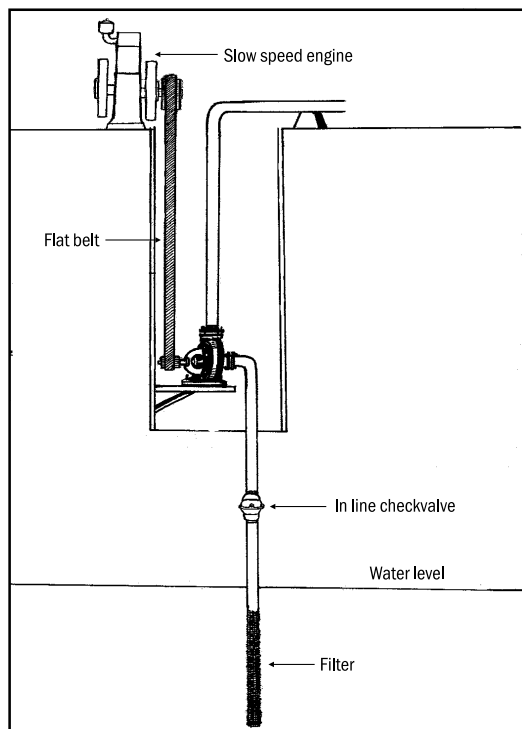

Figure 16 Typical deep-set arrangement with slow speed engine and belt drive

Box 4 Two types of engines

High speed diesel engine

These are mostly derivatives of Petter design originally from the UK. They come in a range of sizes such as 3.5, 5, 6.6 hp and 10 hp at speeds from 1500–2200 RPM. The most popular model is the 5 hp/1500 RPM version. Since most pumps are designed to work between 1400–3000 RPM, no gear-up or gear-down is required and the pumps can be directly coupled to the engine. Most directly coupled pump sets consist of a separate engine and pump, mounted on a common base plate, and connected through a coupling. Another way is to integrate the pump with the engine and mount the pump impellor directly onto the crankshaft of the engine. This is called a ‘mono-block’ pump set. The advantage of a mono-block pump set is that it is considerably lighter and more compact.

Apart from the Petter model engines, there are the more modern Hatz and Lombardini type engines made in India by companies such as Crompton Greaves and Kirloskar. Although lighter than the Petter type engines, these new models have not gained much acceptance yet in the market because the farmers generally do not like the high speed at which they run (about 2500 RPM) and the corresponding wear and tear expected.

Low speed diesel engines

Of the low speed diesel engines, only **the type whose roots can be traced back to the English ‘Lister’ engine** can be found. It comes in various capacities such as 6 hp at 600 RPM, 8 hp at 800 RPM, and 10 hp at 1000 RPM. Unlike the Petter-type engines, it is quite easy for the users to set the speed of these engines. In the field, the actual speed at which they run can be as low as 300 RPM. At such low engine speeds, pumps have to be driven by belts, using a small pulley on the pump and a bigger pulley on the engine to ensure that the pump operates around 1500 RPM. Because they need a belt drive anyway, this type of engine is usually preferred for deep-set pumps.

The low speed engines are believed by the farmers to be more sturdy and longer lasting than the high speed engines. This is probably true because, all other factors being equal, the longevity of an engine is determined by the total number of revolutions it makes, rather than by the number of hours run as is sometimes believed. Assuming that an engine can make 500 million revolutions before needing a major overhaul, a low speed engine at 600 RPM, operating 700 hours per year, can run 20 years before it reaches that point. A high speed engine at 2400 RPM will require such an overhaul after 5 years.

- For shallow pump sets about 40%–50%
- For deep-set pump sets about 25%–45%.

For shallow pump sets the estimated potential for fuel saving is somewhat lower than that for northern West Bengal because in other parts of India check valves associated with lower friction losses are already in use.

Deep-set pumps are not used in northern West Bengal because the water table is not deep enough to require this arrangement.

However, having observed such pumps in areas with deep water tables, it would seem that in most cases considerable improvement in fuel efficiency may be achieved because of the following reasons.

- 1 All these pump sets are cooled by passing pump water through the engines at a flow rate that is too high and the engines are consequently overcooled. Fitting a flow-restrictor will probably improve the fuel efficiency by about 10%, as for the high speed pump sets.
- 2 Most of the low speed pump sets discharge about 10 litre/second whereas the pumps are 10 cm or 13 cm in diameter, designed for 16 litre/second and 23 litre/second discharges, respectively. It is possible to increase the pump efficiency by 20%–30%, by fitting an impellor designed for actual operating conditions.
- 3 Speed reduction of the engine will also contribute to improved efficiency but not as much as for the high speed pumps because the farmers generally reduce the speed themselves.

Altogether, it seems reasonable to expect that by optimizing the cooling and changing the impellor, removing the check valve (where possible), and, in some cases, reducing the engine speed, fuel saving of about 35% can be achieved. This assumption however still needs to be confirmed by testing the proposed modifications. A summary of the expected fuel efficiency improvements for deep-set low speed diesel pump sets is presented in Table 2.

If the average fuel efficiency can be improved by 45% for shallow pump sets, and 35% for deep-set pump sets, the overall average improvement is estimated to be 40%. The potential national impact will then be as indicated in Table 3. Conclusions on the potential impact are presented in Box 5.

The impact is obviously important from the macro- and micro-economic points of view, but it is equally, or, perhaps, even more

important from an environmental point of view in terms of reducing air pollution and the emission of the greenhouse gas CO₂.

Table 2 Expected fuel efficiency improvements for deep-set low speed diesel pump

Improvement	Percentage	Cumulative saving (%)
Introducing flow restrictor cooling or drum cooling	10	90.0
Introducing low friction foot valve	5	85.5
Replacing existing impellor with a more suitable one	20	68.5
Reducing engine speed	5	65.0

Table 3 Potential fuel savings at a national level

Item	Quantity
Assumed total number of diesel pump sets	6 million
Assumed average annual operating time	500 hours/pump
Assumed average fuel consumption	1.1 litre/hour
Total annual fuel consumption of all irrigation pumps	3.3 billion litres
Potential fuel saving through modification (40%)	1.3 billion litres/year (not clear)
Total annual consumption of high speed diesel in India ¹	28 billion litres
Relative saving on the total consumption	5%
Annually imported diesel (1994/95)	9 billion litres
Potential saving on high speed diesel import	15%

¹ Source TERI (1997)

Box 5 Conclusions on potential impact

- The fuel efficiency of most diesel pump sets used for irrigation all over India can probably be improved by about 40% by adopting minor modifications
- The portability of pump sets is being increasingly viewed as important. The newly introduced 2.5 hp pump set weighs only 105 kg compared to the 220 kg of the 5 hp pump sets in use at present.

Assuming further that the proportion between the diesel consumption of irrigation pumps and the total consumption for all diesel requirements is reflected in the transportation needs for diesel, it can be

argued that the diesel required to power tankers, trains, and trucks will also be reduced by 5%. In other words, savings on the direct fuel requirements of irrigation pumps will also create proportional savings in the energy required for distribution of the fuel.

References

Patel S M. 1988

Low-cost and quick yielding measures for energy consumption in agricultural pumps
Pacific and Asian Journal of Energy 2(1): 3–11.

TERI. 1997

TEDDY (TERI Energy Data Directory and Yearbook 1996/97)
New Delhi: Tata Energy Research Institute

Manual pumps: the personal touch

Pumps with a history

Water has been lifted for irrigation using a range of manual devices in the Terai plains since the early ages. These comprise the traditional rope-and-bucket pumps, swing buckets, and pumps very similar to the Dhone pump, popular in Bangladesh (Fraenkel 1997). Hand pumps (Figure 1) were introduced into the region later, followed by treadle pumps. All these pumps are testimony to the low cost of labour in the region.



Figure 1 Hand pump, used for drinking water and vegetable irrigation

The preference for any particular manual device has its rationale and each technology has its own niche. Hand pumps are generally fitted on a tube well, made of bamboo, polyvinyl chloride or galvanized iron and are mostly installed in courtyards. They are relatively safe sources of drinking water, and can be used to irrigate small kitchen gardens (up to 0.2 ha). They are generally not installed outside courtyards for fear of theft.

In open fields, rope-and-bucket pumps are commonly used to irrigate crops. They lift water from extremely shallow digs in the fields (*katcha kuan*) and are operated with either a bamboo spring or a counterweight. The rope-and-bucket pumps are most useful where water tables are very high, but are of little use for lower water tables. These pumps are similar to the *chadouf* found in Egypt, Sudan, and Tunisia. The Dhone type pump is used in low-lying areas to lift water from a stream directly to adjacent lands.

The most recent manual device on the market is the treadle pump (Figure 2). Though popular in Bangladesh, the treadle pump was virtually unknown in the Terai until the mid-1990s. It was introduced and promoted through private retailers, unlike the hand pump, which was provided through government-sponsored programmes. The promotion of treadle pumps by rural marketing is described in chapter 8.



Figure 2 The recently introduced treadle pump

In this chapter different manual pump technologies are compared – in terms of technical performance and social acceptability. The following section describes the results of the test, which focused on the actual water output, but also considered a number of social aspects, such as ease of operation. The last section describes additional arguments that play a role in farmers' choices.

A comparative test

Methodology

A comparison was made between the performance of the standard cast-iron hand pump (mark 6), several models of treadle pump, and the rope-and-bucket pump.

A number of variables were included in the test to obtain a comprehensive picture

of the actual field performance of different manual devices. One was the depth of the water table, as the pumps have quite different outputs depending on the depth of the water. Another variable accounted for the sex and the person operating the pump. Since manual labour is involved, there will be a difference in the output of a strong man and a child. The performance will also depend on the duration of pumping—a labourer can work harder for shorter intervals, but will work at a more measured pace when the pump is to be operated from morning until evening to irrigate a field. The details of the test variables are shown in Table 1.

Testing was carried out in an open well with the pumped water being channelled back into the well (Figure 3). In the first round of testing, all seven types of manual pumps were tested (one hand pump, four types of pedal pumps, and two types of bucket pumps), with different subjects pumping for one hour. In the second round, tests were conducted over an eight-hour period in one day, with the operator taking breaks at his/her own convenience and for as long as he/she felt necessary. In assessing the one-day capacity, lunch breaks were excluded from the eight hours; short breaks of a few minutes each were included in the calculations. In this second round of tests, the operators used a hand pump, one type of rope-and-bucket pump, and two types of treadle pumps.

Actual output

Several parameters can be used to assess the actual performance of the manual pumps, one of which is the effective discharge or flow rate. Another is the one-day capacity, i.e., how much water can be pumped during a normal eight-hour working day.

Table 1 Test variables

Variable	Type	Specifications	1 hour	8 hours
Pump	Hand pump	Cast-iron lever-type (mark 6)	✓	✓
	Pedal pump	(1) Steel pedal, 3.5 inch diameter, 9 inch cylinder	✓	
		(2) Bamboo pedal, 3.5 inch diameter, 12 inch cylinder	✓	✓
		(3) Steel pedal, 5 inch diameter, 9 inch cylinder	✓	
		(4) Bamboo pedal, 3.5 inch diameter, 14 inch cylinder	✓	✓
Bucket pump	Bamboo spring lever Bamboo counter weight	✓ ✓	✓ ✓	
Depth	2.5 metres	—	✓	✓
	5 metres	—	✓	✓
	7 metres	—	✓	✓
Test person	Man	52 kg	✓	
	Woman	42 kg	✓	✓
	Child	34 kg	✓	✓

**Figure 3 Controlled testing of manual pumps**

Flow rates

The most significant finding was that the output of the treadle pump with the 5-inch cylinder was much higher than that of all the other pumps (Figure 4). At shallow depths the flow rate was more than 1 litres/second for all the persons operating the pump (1.06–1.29 litre/second), which did not occur in any other case. The other pumps operated in more or less the same range (0.54–0.69 litres/second for the woman, 0.65–0.74 litres/second for the man, and 0.46–0.65 litre/second for the

child). At greater depths the flow rate for the 5-inch treadle pump dropped dramatically and became equal to or even less than that of the other pumps (0.29–0.49 litre/second). Here, the 3.5-inch treadle pump performed better (0.36–0.48 litre/second). This is because of the difference in diameter—a larger diameter allows more water to be pumped, but also requires more power. Interestingly enough, the performance of the other systems was in the same range.

The graphs show that the man can lift the most water, and the woman follows close behind. At greater depths, body weight becomes a limiting factor particularly for the 5-inch pumps and the other pumps perform better. The child and the woman were more comfortable on the 3.5-inch treadle pump.

One remarkable finding of the test was that treadle pumps with a longer cylinder yielded 20% more water. This was probably because the ratio of pumping time (upward movement) to non-pumping time (downward movement) was higher.

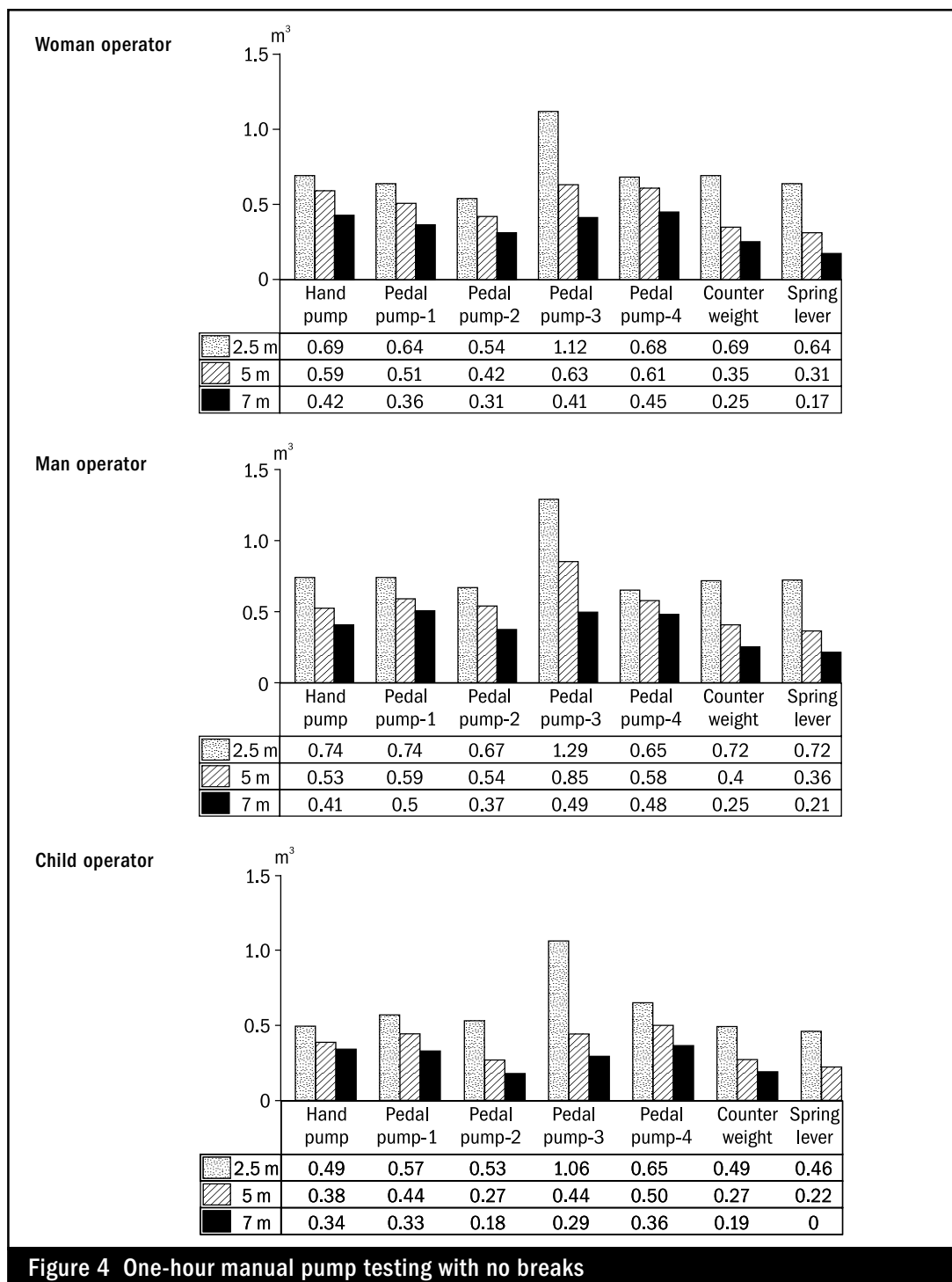

The performance of the bucket pumps was fairly good, especially at shallow depths (Figure 5). This fully explained the popularity of these devices in the field. However, at greater depths problems arose (Box 1). Of the two types tested, the people preferred the counter-weight type over the spring-lever type.

The discharge data should be taken as relative rather than absolute, especially for the pedal pumps, because the actual discharge values depend largely on the operator. This variation is not only due to body weight or age but also the operator's stamina. During a demonstration of the treadle pump, on one occasion, a simple test showed that at a total lift of 5 m, a 3.5-inch bamboo-type treadle pump, operated for half an hour, had a discharge of 1.4 litre/second with one person, 1.0 litre/second with another person and 0.5 litres/second with a third. The first person was a self-employed mechanic, installing and promoting treadle pumps; the second was the farmer who owned the pump; and the third was someone reputed to have a rather laid-back attitude to work.

Box 1 Too scared to pump

As part of the manual pump tests, a child had to operate the bucket pump at different depths as specified. For the treadle pump and the hand pump, the operator is at a safe distance from the well but the bucket pump, requires direct lifting. This poses a problem if the water level falls to say, seven metres because the child is afraid to push the bucket down that deep. For the counter-weight model, it was still acceptable, but with the spring-lever, his nerves gave in—he was too scared of falling into the well!

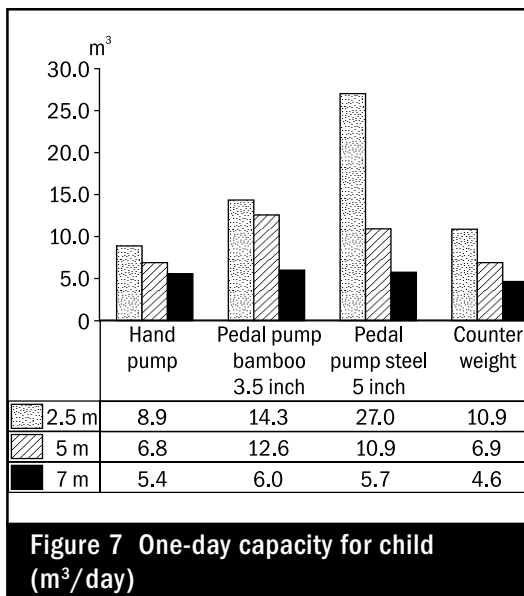
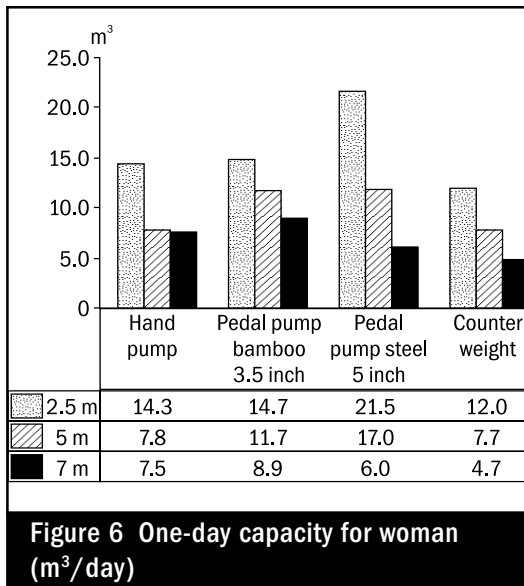

Figure 5 Operating a bucket pump

One-day capacity

Tests were also conducted by pumping for 8 hours to assess the daily capacity. This is not an unusual duration for this region where people use pumps almost throughout the day, with or without shifts, especially when rice fields are being irrigated. These tests were conducted only on the woman and the child, because the difference between the results of the man and the woman in the earlier tests was marginal.

The one-day output of the 5-inch treadle pump is the highest at shallow depths, at 21.5–27.0 m³ per day (Figures 6 and 7). For the woman this pump also gave the best results at medium depth, but for the child the 3.5-inch type performed better. At the



deepest level the 3.5-inch pump gave the best results for both test persons.

There was nearly a 50% reduction in the discharge of the hand pump operated daily for 8 hours, compared to that used for one

hour. This pointed to the lower ergonomic efficiency of the pump's mode of operation (*see* also the following sub-section on the other parameters). For treadle pumps the reduction was only 10%–20%, except where the 5-inch steel pedal pump was used at a depth of 7 m, for which it is clearly not suitable.

On calculating the one-day capacities, it becomes clear that

- the capacity depends more on the flow rate than the number of breaks;
- pedal pumps with 5-inch cylinders perform the best, but show a tremendous drop at greater depths;
- at greater depths the 3.5-inch treadle pump has the best performance; and
- bucket pumps and hand pumps do not differ much.

Other parameters

There are a number of other non-technical reasons that play a more important role in determining the preference for a certain manual pump. Some of these are the ease of operation, the purpose for which the pump is used, and the investment costs.

Ease of operation

While testing the pumps, the subjects were asked to indicate their preference. At the same time the number of breaks and the time taken for these breaks was closely monitored. Observations indicated that the number of breaks increased with depth, which is quite natural, because it becomes more and more difficult to pump the water. Another interesting observation was that treadle pump operators hardly required breaks – the pumps are simply more user friendly. The subjects were able to pump continuously for four hours, which

would have been impossible for the hand-and-bucket pumps. It is interesting to note that the preference of the subject depended completely on the purpose of pumping.

Irrigation water versus drinking water

When water was to be lifted for irrigation, the subjects clearly preferred the treadle pump. These pumps yield more and are much easier to operate continuously for longer hours. The subjects also indicated that they could operate a counter-weight pump for a whole day, but avoided it because of its lower capacity.

In lifting water for drinking, the counter-weight bucket system is preferred. This is a very simple system and nicely suits the purpose of lifting a few buckets only. The ease of operation does not really play an important role here. The treadle pump is not preferred, because in the Terai's cultural setting, water that has been touched by the feet is not offered to one's social superiors. One way to avoid this is to pump the water by hand, using only one cylinder. However, the health aspects are not considered here. A properly constructed hand pump, with a concrete platform and a drain for removing the spilled water is a

much better option. Bacteriological tests on hand pumps showed that 85% of them yield safe water according to the World Health Organization standards in contrast to the ubiquitous dug wells that are almost always contaminated.

Perhaps the rope and washer pump (Figure 8) could be the new technology for the Terai plains, as in Nicaragua (Box 2). This pump provides safe drinking water as well as sufficient flow to irrigate a kitchen garden.

Investment costs

A rough indication of the specific costs for the different devices is given in Table 2. The treadle pump with bamboo pedals and a bamboo tube well is clearly the cheapest option, while the hand pump is the costliest. The



Figure 8 Rope pump installed on a dug well

Box 2 Rope and washer pump: promise for the future?

Also called the 'rope pump', it originated in its present form in Nicaragua but it probably originated hundreds of years ago in China. It combines simplicity of construction and efficiency, particularly at low-lift heads. One pump that was tested had a good discharge of about 2 litres/second at 2 m depth. Although the mechanical and volumetric efficiency of this pump is higher than that of the treadle pump, its ergonomic efficiency is lower because it is hand, rather than foot operated. This also makes it less attractive for use in irrigation. However, it can be fitted on an open well, to pump water for drinking vegetable plot irrigation. There are a large number of such wells in the Terai plains and equipping them with such a pump will allow wells to be covered, rendering them more hygienic - a major advantage.

Table 2 Cost of manual water lifting devices

Water lifting device	Cost of well (\$)	Cost of device	Total cost
Hand pump	53	16 (pump) + 11 (platform)	80
Pedal pump (bamboo) 3.5 inch	3 (bamboo)/26 (GI ^a)	8	11 (bamboo)/ 34(GI)
Pedal pump (steel) 3.5 inch	3 (bamboo)/26 (GI)	18	21(bamboo)/ 44(GI)
Pedal pump (steel) 5 inch	3 (bamboo)/26 (GI)	32	35(bamboo)/58(GI)
Bucket system	33	3	36

^a Galvanized iron

bucket pump is midway, but since digging the well is the most expensive part, the cash expenditure is relatively, the lowest.

Pumps with a future?

In the preceding section a number of criteria for evaluating the performance of manual pumps were described. While looking at the future of manual pumps, two basic factors will play a role. One is the convenience or flexibility of use in the field and the second is the availability of labour versus the availability of funds.

Convenience

Installing hand pumps in the middle of the field is a risky proposition, with the danger of theft always present. Removing and fitting hand pumps is a laborious job and therefore they are always permanently placed in a courtyard, where they can be easily used for domestic purposes and can also irrigate a kitchen garden. The bucket system can be placed in the field, as it is not so prone to theft, the bucket being taken home in the evening. However, the problem with this pump is that it has to be installed at a dug well and pits cannot be dug nor the entire bamboo lever system installed at several places. This shortcoming paves the way for treadle pumps.

A treadle pump can lift water from dug-wells, tube wells, and local streams. The treadle pump can be removed easily at the end of a day and refitted the next day. With the bamboo treadle pump the entire bamboo construction can be left in the field and only the two cylinders have to be carried home. Local manufacturers of this pump have recognized this need and sell these fitted with a handle for carrying! Using this simple technology, one pump can be used for several wells, spread over a number of fields, which is an advantage in irrigation—the water has to flow over a shorter distance and, therefore, the losses are minimized (Figure 9). Another important

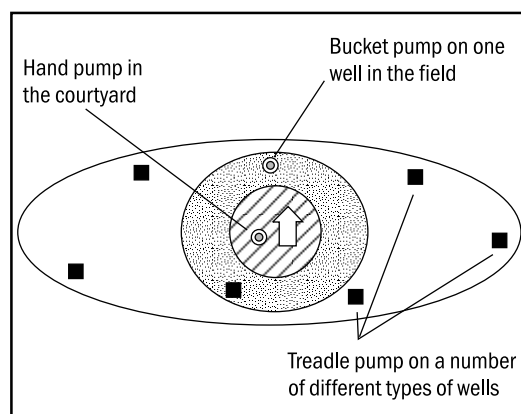
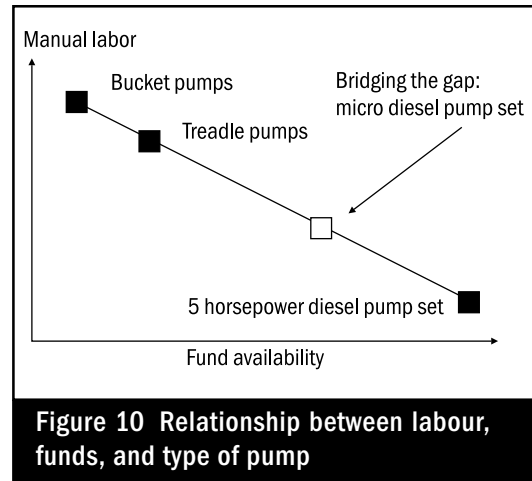

Figure 9 Radius of action for manual pumps

advantage is that the pump can be rented out with or without an operator. A landless labourer can start operating in the water market with this simple device. It has been observed that farmers purchase several treadle pumps at a time so that different members of the family can pump simultaneously on different plots, or all together at one plot. Because of its light weight, people prefer the 3.5-inch treadle pump to the technically better performing 5-inch type.

Availability of labour and funds

As indicated in the introductory section, manual pump devices are an indication of the availability of low-cost labour. The devices described in this chapter all have the advantage of being low-cost and therefore, within the reach of most smallest and marginal farmers. An exception to this is the hand pump. When labour gets scarce and becomes the limiting factor, either because family labour is not available or the, land holding is too large, people search for other alternatives. The treadle pump in that case provides an option that can bridge the gap somewhat but also limits the daily output.



Diesel pump sets (5 hp [horsepower]), fitted on a tube well or dug well are the next best, but funds will be a major constraint for many. There seems to be a niche for small-hp micro diesel pump sets (Figure 10).

Reference

- Fraenkel P. 1997
Water-pumping devices: a handbook for users and choosers
 London: Intermediate Technology Publications

Tube wells: springs of resistance

Small-holder groundwater source

In the Terai region, like in other areas with shallow groundwater conditions, there are a large number of wells, which farmers use to irrigate their small holdings. There are different types of wells, shallow tube wells, dug wells with concrete rings (*pucca kuan*), or with bamboo fencing against collapsing (*katcha kuan*). These wells are installed either by individuals or as a part of government programmes. The predominant type is the shallow tube well, which is fitted with a diesel pump set at ground level so that the water is within suction reach of the pump. Shallow tube wells are very cheap, especially when indigenous materials are used. A bamboo tube well with a bamboo filter costs less than \$ 22. In government programmes, the specifications tend to prescribe far more costly wells with GI (galvanized iron) pipes and brass filters. The tube well is a reliable way of tapping groundwater for irrigation. In the Terai region, shallow tube wells are drilled by the hand percussion (or sludge) method. Whenever a stony layer is encountered, the alternative is to dig an open well, i.e. a dug-well. This type of well is costlier and generally yields less water. A recent development is the 'stone hammer' technique, which makes it possible to construct tube wells in stony layers also. This interesting technique is explained in chapter 5.

This chapter describes the research on improving the performance of the tube

wells mentioned above. The following section deals with shallow tube well design, focusing specially on the filter. The last section describes ways to improve existing tube wells by washing.

Improved shallow tube well design

A shallow tube well has two basic components, a plain pipe and a filter. The plain pipe reaches the water-bearing layer (or

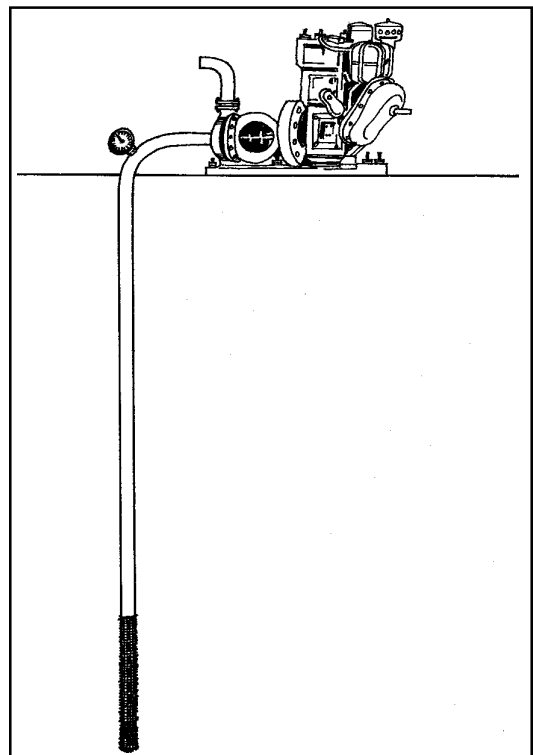

Figure 1 Pump set, well, and vacuum gauge

aquifer) from the ground level and a filter is attached to the lower end of the plain pipe. The function of the filter is to allow the water to flow into the plain pipe, while keeping the sand out. The plain pipe carries water to the surface. There are a variety of designs and materials available for the plain pipe as well as the filter.

An initial survey provided a general idea of the performance of these wells. In the survey a vacuum gauge was fitted between the pump on the suction side and the tube well plain pipe (Figure 1) to read the total suction lift for the pump. One of the crucial aspects in this survey was the filter loss and to determine this the SWL (static water level) was measured before starting the pump. While the pump was operating *the* vacuum gauge registered a much higher suction lift than that expected given the measured SWL, in some cases it was double that or even more. The results of this initial survey are given in Table 1.

A series of experiments was conducted at a test site where the hydrogeological

characteristics appeared to be representative of a large part of the Terai plains. A year and a half and more than 30 experiments later, a

Box 1 Improved tube well design

The improved design incorporates the following features.

- An improved low-cost bamboo filter, with fewer net wrappings (one instead of three) and a spacer ring every inch instead of every foot
- An improved drilling technique. Normally after lowering the filter into the well, the annular space around it is back-filled with sand from the aquifer. If smaller fractions of this sand are washed out before back filling, and if backfilling is done with coarser material, the performance of the well is improved
- Low-pressure class polyvinyl chloride plain pipe instead of the high-pressure pipes used previously. This makes no difference to the performance but it does reduce the cost.

Table 1 Results of initial filter loss survey

Parameter	Mohit Nagar	Falakata	Caoukati	Hemkamari	Kashiabari	Farikpara
Well depth/type/diameter (m / - / inch)	38/GI ^a /3	17/PVC ^b /3	41/GI/3	24/GI/3	25/GI/3	23/PVC/3
Filter length/type/diameter (m / - / inch)	6/brass/3	4/PVC/3	4/PVC/3	4/PVC/3	6/Rods/3	6/PVC/3
Static water level (m)	3.9	2.9	6.5	0.6	0.8	1.0
Assumed dynamic water level (m)	5.4	4.4	7.0	2.1	2.3	2.5
Discharge (litres/second)	7.9	12.1	4.4	9.4	6.5	8.2
Vacuum reading (m)	9.2	7.2	10	6.6	6.3	6.6
Estimated relative filter loss (m/l) ^c	0.48	0.23	0.68	0.48	0.62	0.50
Filter loss (m)	3.8	2.8	3.0	4.5	4.0	4.1
Filter loss (% of dynamic water level)	70	64	43	214	174	164

^a Galvanized iron; ^b polyvinyl chloride; ^c Rather than using the simple term 'filter loss' it was decided to link the filter loss to the discharge and call it 'relative filter loss' because a higher discharge will cause a higher filter loss and *vice-versa*.

filter was designed with a relative loss of only 0.1 metre/litre second. This translates to an average improvement in discharge from 8 litres/second to 13 litres/second with the same fuel consumption. The tests conducted and the aspects considered are described in the following sections. The study concentrated on low cost technology because one of the parameters for improved wells was the cost to small farmers. Interestingly enough the low-cost design was superior in performance to the more costly alternatives. A summary of the optimal tube well design aspects is given in Box 1.

The methodology

After the initial survey, five test wells were constructed 5 m apart. All the wells had the same depth, and the same 3-inch GI plain pipe, but were fitted with different filters. Each well had a 1.5-inch observation pipe installed on the outside of the plain pipe, which was lowered together with the plain pipe and filter. The actual dynamic water level could be monitored while pumping using the observation pipe. Tests revealed that the actual draw-down was roughly equal to what was assumed in the initial survey. Figure 2 shows the actual draw-down as a function of discharge. It should be noted that in this chapter we are concerned with the draw-down of the water table at the borehole itself, because this affects the pump discharge and energy input. These tests confirmed that the filter losses¹ were indeed as high as assumed and that the main problem was the extreme friction loss in the filter. This appeared to be related to the fact that the total number of

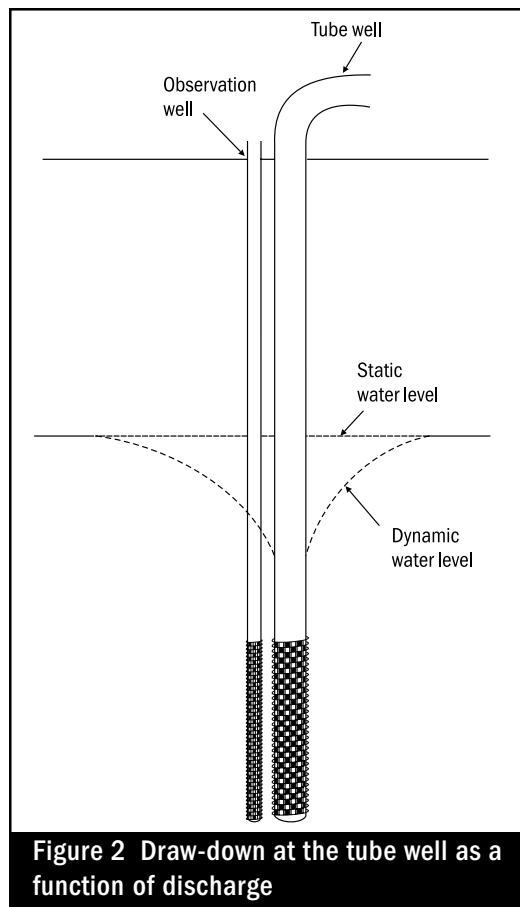

Figure 2 Draw-down at the tube well as a function of discharge

slot openings in the filter was too little, causing water to flow in at a very high velocity. As this carried the sand particles to the filter, the filter became clogged.

Next, nearly 80 experimental wells were constructed (Figure 3). Initially, variables such as type of netting, frame, and length of frame were tested and later others, including frame design, number of net wrappings, distance between filter rings, and grading of the backfilling sand, were added. This long process of trial and error gradually led to an

¹ The filter loss is defined as the total resistance in the flow of the water, starting from where it leaves the aquifer up to where it enters the plain pipe.



Figure 3 Drilling in progress for a shallow tube well



Figure 4 A bamboo filter with mosquito net wrapping

improved design. A quick run-through of the experiments is given below but more details are provided in Annexe 1.

Filter net

The test concentrated on bamboo filters – the most popular technology and, because of its low cost, the most promising. A bamboo filter consists of a skeleton, usually made of bamboo rings and lateral bamboo strips, wrapped with mosquito net (Figure 4), nylon woven fabric (from fertilizer packaging), or coir rope. The wrapping materials tested were typical of those used locally by well-drilling mechanics. The results of these tests show that at the given filter length of 1.8 m, the coir rope had the worst performance, followed by the iron wire net. There was no significant difference between the different mesh sizes of mosquito net and the fertilizer packing material. However, a thick variety of mosquito net (known as nr.12 thick type) was decided upon, as it seemed stronger and so more suited to this purpose. A too-small open area will cause clogging, as observed in the PVC (Polyvinyl chloride) slotted filters.

Annexe 2 provides some more information on the grain size of the aquifer layers.

Different types of frames

Although the filter frames are usually made of bamboo, sometimes they are also made of a number of lateral metal round rods fixed to iron rings (Figure 5). This type has an advantage over bamboo frames in that they can be extracted and recovered along with the plain pipe in case of well failure. It is also said to last longer. A tapered iron rod filter was also tried. The rationale for this design was that as the filter tapers down towards the bottom, the upward flow velocity inside the filter should be more or less constant as opposed to cylindrical filters where the flow velocity varies between zero at the bottom to maximum at the top of the filter. As a novelty a slotted PVC filter type was also tested with a wrapping of mosquito net around it to keep the sand out of the 2-mm slots.

Tests showed that the latter design (PVC filter) performed worst of all. The tapered version of the iron rod filter performed much the same as the other frames, only

the double length filter did significantly better than the other types. This seemed to justify the conclusion that a larger filter is preferred, i.e., 3.6 m instead of 1.8 m, with a normal shape and made of either bamboo or iron rods.



Figure 5 An iron rod frame

Number of wrappings

Having thus settled the type of net, the type of frame, and the length of the frame, the next thing was to discover the most suitable/optimum number of wrappings. Since a portion of the net's mesh tends to overlap as each additional layer is wrapped, the apertures through which the water can flow become smaller with an increased number of wrappings. Three tests were carried out using one, two, and three layers of wrapping. The results clearly showed that for a higher

discharge, fewer wrappings (one or two) were better, preventing the filter from getting quickly clogged, because of the high entry velocity of water. However, it remained to be seen whether a single layer alone could keep the sand out and whether it was strong enough. It was nevertheless decided to continue with a single wrapping only.

Frames again

Although the iron rod frame had performed the best so far, it was more costly than a bamboo frame. It was decided to test the bamboo and PVC frames again, this time using only one wrapping, and instead of bamboo rings, PVC rings were used. The bamboo rings, with their relatively narrow inner passages, were expected to cause high friction losses for the water flowing vertically upwards through the filter. This was a problem that PVC rings (sections cut from PVC pipes) would not cause. The result was that the bamboo frames now performed as well as the iron rod frames. The slotted PVC pipes with a single wrapping performed poorly. An estimation of costs showed that for 3.6 m, a bamboo filter costs \$ 3, an iron rod filter cost \$ 26, and a PVC filter \$ 22. When performance and cost are considered, bamboo frames are clearly superior.

Filter diameter

A larger filter diameter, i.e. 4 inches instead of 3 inches was tested and was not found to perform better so the test was not pursued any further. The extra cost of drilling the larger hole would have made this an unviable proposition, anyway.

Filter length

Two different lengths of bamboo filter, 2.4 m and 5.4 m, made of PVC rings with a

single wrapping, were tested. Surprisingly, the shorter filter performed considerably better than the longer one, especially in terms of relative filter loss. This suggested that the filter was not strong enough. With the rings spaced 30 cm apart, the netting of the filter could be drawn inwards through the slots between the strips and so throttle upward flow in the filter. This was especially likely to happen after installation, with cow dung mixture partly clogging the filter and creating a strong vacuum. These tests on filter length triggered more tests on the strength of the filter and a 3.6 m length was suggested, in order to have some additional filter length available in case of clogging.

A strong design with gravel packing

To test the idea of collapsing filters, four filters were installed with only 2.5 cm between the rings (instead of 30 cm as earlier) (Figure 6). In addition, a steel wire was wound around the strips before fitting the net, to provide extra internal support, and sieved sand (*see* Annexe 2) was used for backfilling around the filter. A combination of the latest filter design and sieved coarse sand for backfilling gave the best results. Farmers however, do not give enough importance to proper packing.

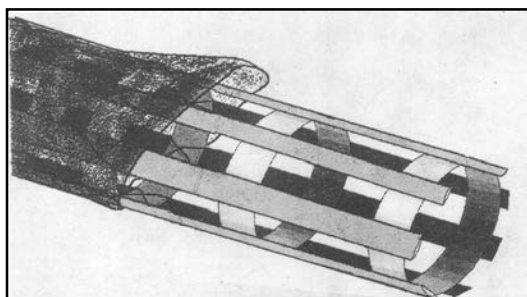

Figure 6 Closely spaced PVC rings for greater strength

Box 2 Summary of improved well design

- The existing bamboo filter has been improved such that it gives 45% better discharge at equal cost. This results in an effective fuel saving of 45%
- Low-cost filters such as those made of bamboo with mosquito net and iron rods with mosquito net, actually perform better than modern high cost filters made of slotted polyvinyl chloride or brass, in the given circumstances
- For low-cost filters, insufficient strength leading to partial or complete collapse is an important reason for high filter loss. This also explains the inconsistency in performance of the same filters in the same conditions
- The importance of using good coarse sand, without the finer fraction, for backfilling around the filter is not appreciated.

Final results

Analysis of the test data shows that the specific filter resistance which was initially about 0.50 metre/litre-second was reduced to 0.11 metres/litre-second. This constitutes an 45% improvement based on the following calculation.

- In the old filter design, a discharge of 10 litres/second from a dynamic water level of 4 m, has a total lift head, as 'felt' by the pump, of 9 m ($4 \text{ m} + [10 \text{ litres/second} \times 0.50 \text{ metres/litre-second}]$).
- With the new filter design (Figure 7), the total lift for the same discharge and dynamic water level is 5.1 m only ($4 \text{ m} + [10 \text{ litres/second} \times 0.11 \text{ metres/litre-second}]$).

In reality, the dynamic water level remaining the same, an improved filter will result in a higher discharge, in this case a

45% increase in discharge for the same power input. This can also be seen as a 45% decrease in fuel consumption because there will be a proportional reduction in pumping time. The real reduction in fuel saving will still be higher because a higher discharge means reduced 'transient water loss' in the conveyance channel, resulting in a further reduction of pumping time (*also see chapter 6 on conveyance*).

In the context of performance, it is also interesting to look at the costs. A 'modern' well with a brass filter and a GI plain pipe with a discharge of 10 litres/second costs around \$ 110. A 'modern' well with a PVC filter and normal PVC plain pipe, with a discharge of 8 litres/second, will cost around \$ 85. A bamboo well, according to the old design, costs around \$ 25 dollars, whereas the new bamboo design, with a discharge of, 14 litres/second will cost around \$ 20. Unfortunately, bamboo filters are neither subsidized nor incorporated



Figure 7 The improved filter

in government procurement programmes. One reason being that they are hard to standardize and specify. This requires re-thinking though, since the bamboo wells are clearly superior in performance and price. For more details see Annexe 2.

Wells for foot pumps

After the test on diesel pump operated wells, tests were carried out to investigate similar efficiency increases in smaller diameter wells, with manually operated pumps. A series of tests were conducted on the wells used in combination with treadle pumps. The tube wells consist of a 1.5 inch PVC plain pipe and a filter made of a bamboo skeleton wrapped with mosquito net or a plastic woven fabric taken from fertilizer bags (Figures 8 and 9). Bamboo is also often used instead of the PVC plain pipe because it is cheaper.

The data shows that there was no measurable difference in the vacuum reading during and just after pumping. This indicates that the sum of the pipe friction and filter loss is negligible for manual pumps, with a much lower capacity than diesel pumps. In other words, the pump's performance cannot be improved by installing a better filter

Box 3 Double profit

A group of farmers at Kalamati (Cooch Behar District) received a heavily subsidized well and pump set from the Panchayat. The well was to be equipped with a galvanized iron plain pipe and a brass-jacketed filter. Several hundred similar configurations were supplied to other groups in the area. They knew from experience that the (expensive) brass filters did not have a good discharge, so before the pipes and filters were lowered, they stripped off the brass jacket and replaced it with mosquito net wrapping. They enjoyed a 20 litres/second discharge against the normal discharge of 13 litres/second and also a handsome profit from selling the brass!



Figure 8 Vacuum gauge reading on a treadle pump to determine well filter resistance



Figure 9 Filters as used for treadle pump wells

or plain pipe of greater diameter. The results of these tests are presented in Annexe 4.

Shallow tube well washing

High filter losses in shallow tube wells have been discussed in the previous sections. One way of solving the problem is to search for alternative filters. A possible cause is blockage of the filter slots (clogging), which can be remedied by some form of washing. To test this theory in the field, two tools were developed, a jetting tool and a surging tool (Figures 10 and 11).

Test results indicated that the wells could in many cases, be improved, but not to the desired level of performance. This led to the conclusion that the problems were related to the wells' design and would not be solved by any amount of washing, thereby stressing the need for the experiments described earlier. However, since washing did seem to have some benefit, it was decided to proceed with the testing on a larger scale, which would also help determine which tool was most effective. In all, 26 wells were



Figure 10 Jetting tool, using horizontal jets



Figure 11 Surging tool

washed in the trial using both methods alternately. The results are presented in Annex 5 while the relative improvement related to the proportion of washed wells is shown in Table 2.

Table 2 Relative improvement after washing, proportional to the number of wells washed

Improvement in discharge after washing	Proportion of washed wells (%)
Less than 10%	15.4
10% to 20%	50.0
20% to 30%	15.4
More than 30%	19.2

The results show that there is no significant difference between the two tools. The jetting process is relatively costly and cumbersome because it requires a pump set, a long length of flexible tube, and a jetting tool. Surging, on the other hand, is extremely simple and requires only a half-inch-long GI tube and a surge piston, which cost no more than \$6.

Well washing with a surge plunger is not entirely new to the local mechanics (Figure 12). It was already practised, albeit rather crudely, by just moving a bamboo pole up and down in the well. Local mechanics have been trained in this improved method of well washing and an explanatory folder has been distributed. Several mechanics now make a business out of well washing, charging around a dollar for the service. In some cases

the satisfied customer has generously doubled the sum paid! Box 4 presents the general conclusions on the washing of tube wells.



Figure 12 A well being washed with a surge piston

Box 4 Conclusions on washing of tube wells

- Well washing generally does increase the discharge, which can be translated to a reduction in fuel consumption. There is a direct fuel saving because with the same power input more water is pumped and there is an additional indirect fuel saving because a higher discharge means less transient water losses in the conveyance channel, reducing the required pumping time
- Washing requires only a very simple tool and costs almost nothing (Rs 300 for the tools and Rs 40-50 for getting it done).

Annexe 1 Calculation of filter loss

Filter type	Well No.	Diameter (Inch)	Depth (m)	Filter length (m)	Discharge (litres/second)	Static water level (m)	Dynamic water level (m)	Estimated dynamic water level (m)	Vacuum on gauge (m)	Friction loss (m)	Velocity head (m)	Real vacuum (m)	Expected vacuum (m)	Filter loss (m)	Relative filter loss (m/l-s)
Net															
Standard mosquito net (fine quality) (honeycomb structure, open area 1.5 mm ²)	1	3.00	6.40	1.80	7.00	2.70	4.40	4.50	8.29	0.50	0.50	7.80	5.70	2.60	0.37
coir rope	2	3.00	6.40	1.80	3.90	2.70	3.60	3.70	9.24	0.50	0.50	8.70	5.10	4.10	1.05
thick mosquito net - (thick quality) (rectangular structure, open area 2.5 mm ²)	3	3.00	6.40	1.80	8.00	2.70	4.40	4.50	8.70	0.50	0.50	8.20	5.70	3.00	0.38
Fertiliser bag	4	3.00	6.40	1.80	8.30	2.70	4.50	4.60	8.29	0.50	0.50	7.80	5.90	2.40	0.29
Iron wire net	5	3.00	6.40	1.80	4.10	2.70	3.80	3.90	8.97	0.50	0.50	8.50	5.30	3.70	0.90
Very fine mosquito net (fine quality) (rectangular structure, 1.0 mm ²)	6	3.00	6.40	1.80	8.10	2.70	4.40	4.50	8.29	0.50	0.50	7.80	5.70	2.60	0.32
Frame															
Bamboo, 7 S ^a , 3 W ^b , iron R ^c	7	3.00	6.40	1.80	8.20	2.60	3.80	3.90	7.82	0.50	0.50	7.30	5.10	2.70	0.32
Tapered, 7 S, 3 W, iron R	8	3.00	6.40	1.80	7.00	2.70	4.20	4.30	8.30	0.50	0.50	7.80	5.50	2.80	0.40
Iron rod, 7 S, 3 W, iron R	9	3.00	6.40	1.80	6.70	2.70	4.40	4.50	8.02	0.50	0.50	7.50	5.70	2.30	0.34
Tapered iron rod, 7 S, 3 W, iron R	10	3.00	8.20	3.60	9.90	2.60	4.10	4.20	7.82	0.50	0.50	7.30	5.40	2.40	0.24
Bamboo, 7 S, 3 W, bamboo R	11	3.00	6.40	1.80	8.00	0.90	2.30	2.40	8.36	0.50	0.50	7.90	3.60	4.80	0.49
PVC, 2 mm slot, 3 W	12	3.00	6.40	1.80	6.20	2.60	3.80	3.90	8.56	0.50	0.50	8.10	5.10	3.50	0.56
Wrappings															
Iron rod (10), 1 W, net number 12, iron R (24)	13	3.00	8.20	3.60	14.50	0.60	3.20	3.30	6.66	0.50	0.50	6.20	4.50	2.20	0.15
Iron rod (10), 2 W, net number 12, iron R (24)	14	3.00	8.20	3.60	12.20	0.60	2.70	2.80	7.40	0.50	0.50	6.90	3.90	3.50	0.28
Iron rod (10), 3 W, net number 12, iron R (24)	15	3.00	8.20	3.60	9.30	2.60	4.10	4.20	6.73	0.50	0.50	6.20	5.40	1.30	0.14

Frame

Iron rod, 7 S, 1 W, net number 12, iron R	16	3.00	6.40	1.80	11.20	1.30	3.70	3.80	7.34	0.50	0.50	6.80	5.00	2.30	0.20
Bamboo, 7 S, 1 W, net number 12, PVC R	17	3.00	6.40	1.80	13.00	1.30	3.80	3.90	7.20	0.50	0.50	6.70	5.10	2.10	0.16
Bamboo, 7 S, 1 W, net number 11, PVC R	18	3.00	6.40	1.80	8.70	1.30	3.10	3.20	8.16	0.50	0.50	7.70	4.40	3.80	0.44
Bamboo, 8 S, 1 W, Net number 12, iron R	19	3.00	6.40	1.80	13.80	0.50	2.60	2.70	7.20	0.50	0.50	6.70	3.90	3.30	0.24
PVC, 2 mm slot, 1 W, net number 12	20	3.00	6.40	1.80	7.00	0.50	1.70	1.80	8.43	0.50	0.50	7.90	3.00	5.40	0.77
PVC, 2 mm slot, 1 W, net number 12	21	3.00	8.20	3.60	9.40	0.50	1.90	2.00	7.75	0.50	0.50	7.30	3.20	4.60	0.5
Bamboo, 7 S, 1 W, net number 12, PVC R	22	3.00	6.40	1.80	10.80	0.30	1.80	1.90	7.30	0.50	0.50	6.80	3.10	4.20	0.39

Diameter

4" Bamboo, 1 W, PVC R (22)	23	4.00	6.40	1.80	8.00	0.30	1.90	2.00	8.16	0.50	0.50	7.70	3.40	4.80	0.60
----------------------------	----	------	------	------	------	------	------	------	------	------	------	------	------	------	------

Filter length

Bamboo, long size PVC R, 7S, O = 6 feet	24	3.00	7.00	2.40	14.30	0.20	2.50	2.70	5.30	0.50	0.50	4.80	3.90	1.40	0.10
Bamboo, long size PVC R, 7S, O = 3.2 feet	25	3.00	8.20	3.60	13.30	0.20	–	–	–	–	–	–	–	–	–
Bamboo, long size PVC R 7S, O = 9 feet	26	3.00	10.00	5.40	12.90	0.20	3.20	3.40	6.90	0.50	0.50	6.40	4.60	2.30	0.18

Strong design

Bamboo, 2-cm PVC ring, O = 3 feet, G = fine	27	3.00	6.40	1.80	9.20	0.20	2.20	2.40	5.80	0.50	0.50	5.30	3.60	2.20	0.24
Bamboo, 2-cm PVC ring, O = 6 feet, G = fine	28	3.00	8.20	3.60	13.30	0.20	3.00	3.20	7.48	0.50	0.50	7.00	4.40	3.10	0.23
Bamboo, 2-cm PVC ring, O = 6 feet, G = coarse	29	3.00	8.20	3.60	15.40	0.20	2.80	3.00	5.90	0.50	0.50	5.40	4.20	1.70	0.11
Bamboo, 2-cm PVC ring, O = 6 feet	30	3.00	8.20	3.60	16.10	0.20	–	–	–	–	–	–	–	–	–

^a Number of lateral bamboo strips used in the filter; ^b number of wrappings of nettings on the filter; ^c number of type/material of the rings used in the filter; ^d polyvinyl chloride; ^e open area in square feet; ^f type of material used for backfilling around the filter after installation, the well is drilled using a 3-inch socket which leaves a bore of about 4 inches and the annular space between the filter and the bore is later filled with sand.

Contd...

Annexe 1 Contd...

Explanations on the calculation of filter loss tables

- *Diameter* Diameter of the filter, always **3 inches (Metric)** except for test number 23
- *Depth* Total depth of the well in m.
- *Filter length* Length of filter used in m.
- *Dynamic water level* The dynamic water level (in m) was measured in an observation well at a 50-cm distance from the test well.
- *Estimated (real) dynamic water level* It has been assumed that in view of the curved shape of the draw-down cone, the real dynamic water level will be 10 cm deeper than the one measured in the observation well.
- *Vacuum* A vacuum gauge (reading in m) was fitted on the tube well casing just above ground level. This gives the total of the dynamic water level plus filter resistance plus pipe friction loss. As the dynamic water level is also measured separately and the pipe friction loss can be calculated, the filter loss can be determined in this way.
- *Friction loss* Calculated friction in the plain pipe, assumed to be an average of about 0.5 m.
- *Velocity head* To be really accurate in measuring the vacuum, this reading must be corrected for the so-called 'velocity head'. The flow of water through the pipe creates a drop of itself (Law of Bernoulli) and so the vacuum gauge gives the sum of the lift head for the pump plus the velocity head. This velocity head can be calculated as follows.
$$H = V^2/20$$
where H denotes the velocity head in m for the water column, V denotes water velocity in m/second, and 20 is a constant for water.
With the given pipe diameter of 3 inches and the flow range of 8 to 12 litres/second, the average velocity head was assumed to be 0.5 m. So if the vacuum gauge reads 6 m suction, the real (corrected) value would be 5.5 m.
- *Real vacuum* The measured vacuum minus the 0.5-m velocity head.
- *Expected vacuum* The vacuum one would ideally expect if there were no filter losses, i.e., the real vacuum minus pipe friction loss minus real dynamic water level.
- *Filter loss* The real vacuum minus the expected vacuum.
- *Relative filter loss* The filter loss in m expressed per litre/second of discharge. Since the filter loss is a frictional loss, its magnitude depends on the flow of the water, just like friction losses in a pipe. It would thus be incorrect to express it as an absolute value. Furthermore, it took a long time to complete all this testing and with the change in season, the water table also changed. By calculating the relative friction loss, the test results at different water tables will be comparable.

Annexe 2 The aquifer in which the filters are placed

At the Haldibari test site, eight aquifer samples were taken at different depths. These samples were analysed and the following tables show the effective grain size and coefficient of uniformity for each depth.

Aquifer composition at Haldibari test site

Depth (m)	Coefficient of uniformity	Effective grain size (mm)
3.7	1.29	0.28
4.7	1.75	0.32
5.7	1.94	0.32
6.7	2.00	0.30
7.7	2.28	0.29
8.7	2.23	0.31
9.7	2.34	0.35
10.7	2.03	0.32

Sample of sieve analysis for 10.7-m depth

Sieve number	Sieve opening (mm)	Percentage retained	Cumulative percentage retained	Percentage of finer particles
1	2.000	2.1	2	97.0
2	1.000	9.9	12	88.0
3	0.500	47.9	60	40.0
4	0.250	37.1	97	2.9
5	0.100	2.1	99	0.9
6	0.063	0.9	100	0.0

Annexe 3 Cost of wells

Typical unit cost for well components in local currency

Component	Cost (Rs)
▪ Bamboo filter, old type, 15 feet length	115
▪ Bamboo filter, new type, 12 feet length	145
▪ PVC ^a filter, 0.3 mm slots, 30 feet	2250
▪ Brass filter (good quality) 30 feet	16000
▪ Brass filter (normal quality) 30 feet	6000
▪ Plain pipe, 3 inch, 20 feet, low cost	220
▪ Plain pipe 3 inch, 20 feet, normal quality	360
▪ Plain pipe bamboo, 20 feet	100
▪ Plain pipe GI ^b , 20 feet (normal quality)	1500
▪ Drilling a 35 feet well (Rs 18/feet)	630
▪ Cow dung and backfilling sand	80

^a polyvinyl chloride; ^b galvanized iron

Typical cost of complete wells (in rupees)

Component	Cost (Rs)
Old type bamboo filter and normal PVC^a plain pipe, for a discharge of about 10 litres/second	
Filter (15 feet)	115
Plain pipe (20 feet)	360
Drilling (35 feet)	630
Cow dung and sand	80
Total	1185
New type bamboo filter and low cost PVC plain pipe for a discharge of about 14 litres/second	
Filter (12 feet)	145
Plain pipe (20 feet)	220
Drilling (32 feet)	576
Cow dung	40
Total	981
'Modern' well with brass filter and GI^b plain pipe for a discharge of about 10 litres/second	
Filter (24 feet)	2700
Plain pipe GI (20 feet)	1500
Drilling (44 feet)	792
Cow dung and sand	100
Total	5092
'Modern' well with PVC filter and PVC plain pipe, for a discharge of about 8 litres/second	
Filter (24 feet)	2700
Plain pipe, normal PVC (20 feet)	360
Drilling (44 feet)	792
cow dung and sand	100
Total	3952

Note \$1 = Rs 46

^a polyvinyl chloride; ^b galvanized iron

Annexe 4 Footpump well resistance test data

Static water level (m)	Vacuum reading after priming (m)	Vacuum reading during pumping (m)	Vacuum reading after pumping (m)	Draw-down (m)	Discharge (litres/second)	Stroke (no./min.)	Cultivated area (bigha)	Plain pipe/ filter length (m/m)	Wrapping (number, type)	Continuous pumping time by farmer (hours)	Pump in use (years)	Well in use (years)
Wells with 1.5-inch plain pipes												
4.05	4.47	5.13	4.47	0.66	0.97	49	2.3	6 / 3	2, mosquito	1.5	1	1
3.9	4.47	4.80	4.47	0.33	0.74	52	1	6 / 3	2, mosquito	1	0.25	0.25
3.9	3.81	4.47	3.82	0.66	1.22	58	2	6 / 3	2, mosquito	1	1	1
3.9	3.81	4.47	3.82	0.66	1.04	60	1	6 / 3	2, mosquito	1	2	2
4.2	4.73	5.26	4.74	0.53	0.83	49	1	6 / 3	2, mosquito	1	0.25	0.25
3.75	4.07	4.47	4.08	0.40	0.95	55	0.75	6 / 3	2, mosquito	3	0.1	0.1
2.85	3.48	4.34	3.49	0.86	0.82	49	1.5	6 / 3	2, mosquito	4	3	2
2.8	3.28	4.40	3.29	1.12	1.21	60	5	6 / 3	2, mosquito	3	3	1
3.3	3.68	4.47	280	0.79	0.98	58	3	4.6 / 3	2, mosquito	3	1	1
–	3.68	4.40	3.68	0.73	0.88	51	2	6 / 3	3, mosquito	0.5	1	0.25
3.65	4.73	7.10	4.74	2.37	0.70	58	0.5	6 / 3	2, mosquito	0.5	0.25	0.25
2.6	3.15	3.61	3.16	0.46	0.96	59	2	6 / 3	2, mosquito	1	0.25	0.25
2.63	3.02	3.61	4.74	0.59	0.89	60	0.25	6 / 3	2, mosquito	1.15	1	1
2.55	2.96	3.48	2.96	0.53	0.85	48	2	6 / 3	2, mosquito	3	1	1
2.8	3.28	3.61	3.29	0.33	0.67	50	1	6 / 3	2, mosquito	3	0.4	0.4
2.5	2.82	3.15	2.83	0.33	0.67	49	0.5	6 / 3	2, mosquito	2.5	10 days	10 days
3.65	4.47	4.60	4.47	0.13	0.95	54	1.5	5.8 / 2.2	2, mosquito	1	0.4	0.4
3.4	3.94	4.60	3.95	0.66	0.75	51	0.75	6 / 3	2, mosquito	1	0.8	0.4
3.8	4.07	4.47	4.07	0.40	1.07	60	0.5	6 / 3	2, mosquito	1.5	10 days	10 days
4.1	4.47	5.26	4.47	0.79	1.09	58	1	6 / 3	2, mosquito	2	0.4	0.4
3.1	3.68	4.86	2.80	1.18	1.12	58	4	6 / 3	2, mosquito	2	0.25	0.25
2.6	2.89	3.68	2.20	0.79	0.94	58	0.5	9 / 3	2, mosquito	1.5	0.4	0.4
4.95	4.86	5.52	3.70	0.66	0.74	65	Demo	18 / 3	2, mosquito	–	–	–

Contd...

Annexe 4 Contd...

Static water level (m)	Vacuum reading after priming (m)	Vacuum reading during pumping (m)	Vacuum reading after pumping (m)	Draw-down (m)	Discharge (litres/second)	Stroke (no./min.)	Cultivated area (bigha)	Plain pipe/ filter length (m/m)	Wrapping (number, type)	Continuous pumping time by farmer (hours)	Pump in use (years)	Well in use (years)
Wells with 1.5 inch bamboo plain pipes												
2.35	2.63	3.88	2.63	1.25	1.14	60	0.5	3.7 / 3	1, urea bag	2.5	2	1
2.0	2.63	3.55	2.63	0.92	1.1	67	0.75	3.7 / 3	1, urea bag	2	2	2
2.45	2.76	4.21	2.76	1.45	1.17	62	0.5	3.7 / 3	1, urea bag	4.5	2	2
2.6	2.76	3.55	2.76	0.79	1.13	57	0.75	3.7 / 3	1, urea bag	2	4	3
1.9	2.47	2.89	2.37	0.53	0.79	51	0.5	4.9 / 3	1, urea bag	3.5	1	0.25
2.0	2.50	3.42	2.50	0.92	1.02	57	1	4.9 / 3	1, urea bag	2	0.25	0.25
2.15	2.76	3.42	2.76	0.66	1.11	62	1	4.6 / 3	2, mosquito net	4	4	3
2.6	3.16	4.21	3.15	1.05	1.04	61	0.5	4.6 / 3	2, urea bag	3	4	4
2.8	3.55	4.87	3.55	1.32	0.85	60	0.5	4.6 / 3	1, urea bag	3	3	3
2.1	2.50	4.47	2.50	1.97	1.42	60	0.5	3.6/1.8	2, mosquito net	6	0.25	0.25
2.4	2.76	3.68	2.76	0.92	0.87	60	0.75	3 / 1.8	2, mosquito net	3	2	4
—	3.42	5.79	3.42	2.37	0.96	49	0.5	3 / 3.7	2, mosquito net	1	1	0.25
—	3.55	4.34	3.55	0.79	0.86	49	0.25	6 / 3	2, mosquito net	2	1	1
3.25	3.55	4.47	3.55	0.92	1.43	62	1	6 / 2	2, mosquito net	1	1	1
1.7	1.84	2.24	1.84	0.39	1.2	62	0.75	6 / 2.4	2, mosquito net	2	0.25	0.25
2.45	2.63	2.89	2.63	0.26	0.58	61	0.5	6 / 1.8	2, mosquito net	2	1	1
3.75	4.20	4.61	4.21	0.39	1.07	61	1	6 / 2	2, mosquito net	2	1	0.25
3.3	3.68	4.61	3.68	0.92	1.31	61	0.5	6 / 2.4	2, mosquito net	0.5	1.5	1.5
2.6	2.76	4.74	2.76	1.97	1.3	61	0.75	6 / 2.4	2, mosquito net	1	1	0.5
3.0	3.00	3.68	3.00	0.66	1.3	60	2	6 / 3	2, mosquito net	1	2	2
3.0	3.00	3.68	3.00	0.66	1.2	60	1	6.7 / 3	2, mosquito net	1	2	2
2.9	3.29	3.95	3.30	0.66	1.23	62	0.5	5.5 / 3	2, mosquito net	1	0.5	0.5
2.9	3.29	3.82	3.30	0.53	1.1	52	1	5.5 / 3	2, mosquito net	1	0.5	0.5

Contd...

Annexe 4 Contd...

Explanation of foot pump well resistance data

- *Plain pipes* Some foot pump wells are made with bamboo pipes of approximately 1.5 inch and some with PVC (polyvinyl chloride) pipes of 1.5 inch. Both types were tested.
- *Vacuum reading after priming* The reading of the vacuum gauge after the pump has been primed, this should be the same as the static water level.
- *Vacuum while pumping* This gives the total lift as 'felt' by the pump. It is the sum of the static water level, the draw-down, the pipe friction and the filter resistance or filter loss.
- *Vacuum gauge reading after the pumping stopped* This is the sum of the static water level and the draw down. Because this reading is taken immediately after the pump stop, it is assumed that the draw-down has not yet been discovered.
- *Well resistance* The sum of the pipe friction loss and the filter loss.
- *Draw-down* The local lowering of the water table due to pumping.
- *Discharge* Pump discharge at a normal pumping rate.
- *Stroke/min.* The frequency at which the pump was operated during the testing. The discharge and other data were measured after about 30 minutes of pumping.
- *Cultivated area* The area cultivated by the pump as reported by the farmer.
- *Plain pipe and filter length* The installed length of plain pipe (bamboo or PVC) and filter, as reported by the farmer.
- *Number of wrappings and filter material* The filter consists of the bamboo strip skeleton, around which a gauze material is wrapped.
- *Continuous pumping time* The time the farmer operates the pump without break, as reported by him.

Annexe 5 Results of well washing

Total depth (feet)	Well age (years)	Plain pipe type	Filter type	Filter length (feet)	Static water level (feet)	Initial discharge (litres/second)	Discharge after jetting (litres/second)	Discharge after surging (litres/second)	Increase increase (second)	Relative (%)
29	2	PVC ^a	Bamboo	14	8.3	16.0	16.5	16.5 ^c	0.5	3
26	2	PVC	Bamboo	10	7.9	10.5	11.3 ^c	11.7	1.2	11
30	10	GI ^b	Rods	13	7	11.4	12.1 ^c	12.6	1.2	10
28	7	GI	Rods	14	7.6	10.1	—	13.0 ^c	2.9	29
60	3	GI	Rods	20	8	8.6	10.0 ^c	9.7	1.1	13
60	5	GI	Rods	20	9.5	8.3	10.5	10.5 ^c	2.2	27
90	8	PVC	Bamboo	20	8	7.1	—	7.7 ^c	0.6	8
40	2	PVC	Bamboo	20	8	5.0	—	6.4 ^c	1.4	28
30	2.5	PVC	Bamboo	10	9	9.5	10.0	10.5 ^c	1.0	11
105	6	GI	Brass	18	4	nil	6.0 ^c	6.7	6.7	100
86	2.5	GI	Brass	18	5	6.8	7.1	7.1 ^c	0.3	4
60	3	GI	Bamboo	20	4	11.2	12.1	12.1 ^c	0.9	8
60	4	GI	Bamboo	20	4	8.7	11.5 ^c	11.5	2.8	32
60	2/3	PVC	Rods	15	3.5	12.0	13.5 ^c	13.5	1.5	13
40	3	PVC	Bamboo	15	4	14.2	—	16.7 ^c	2.5	18
95	—	GI	Brass	18	4	10.0	11.1 ^c	11.76	1.7	17
60	2.5	—	—	18	4	9.1	10.5	10.5 ^c	1.4	15
60	5	PVC	Bamboo	20	3.5	11.5	13.1 ^c	13.0	1.5	13
58	10	GI	Brass	18	4	7.1	10.5	10.5 ^c	3.4	48
62	1	PVC	Bamboo	22	4.5	9.1	9.5 ^c	10.0	0.9	10
60	7	PVC	Bamboo	20	4	11	—	12.5 ^c	1.5	14
84	2	GI	Rods	24	3.4	9.5	10.5 ^c	10.7	1.7	18
64	6.5	GI	Bamboo	24	4.6	11.1	—	13.4 ^c	2.3	21
75	1	GI	Bamboo	20	4	8.6	—	9.5 ^c	0.9	10
137	4	GI	Brass	18	2.5	nil	2.0	3.6 ^c	3.6	100
60	3.8	PVC	Rods	20	3	12.1	13.4	13.4 ^c	1.3	11

^a Polyvinyl chloride; ^b galvanized iron; ^c Indicates the method used first (jetting/surging)

The stone hammer: in difficult territory

When hard layers obstruct

Wherever possible, landowners will dig shallow tube wells. The rapid growth of shallow tube wells in the Terai – the number of shallow tube wells increased by a factor of 2.5 in the last ten years – is evidence of this. However, there is a large tract with hard layers made of rocks or heavy clay in the Terai, where the hand-sludge method for making tube wells described in chapter 4 will not do. In such areas farmers are resigned to the considerably more expensive dug-well technology. The diameter of these dug wells is typically between 1.3 m and 2.0 m. After a well approximately 1.5 m deep has been dug, rings are installed one by one in the well. When approximately five rings are in place, the soil is removed manually. The rings drop as digging proceeds and new rings are positioned on the earlier ones.

The cost of a dug well varies, but generally it is of the order of \$400–450 for a 30 feet-deep well with a diameter of 1.3 m. This is a lot more than the cost of a shallow well, as little as \$20 in soft soils. However, worse than the cost is the unreliability of the dug wells. The hand digging in water-bearing strata means that the construction season is confined to a short period, when the water table is at its lowest. Even then digging sufficiently deep is difficult and many dug wells suffer from rapid draw down, if they produce water at all. Interviews with local dug-well mechan-

ics and a non-random sample of 50 dug wells (Institution of Engineers 1996) indicated that more than 35% of dug-wells failed.

Wells with problems fall into two basic categories.

- 1 Dug-wells suffering from sand ingress (quicksand stream) filling up the lower rings of the dug-wells and ultimately obstructing the entry of water. This phenomenon also leads to a caving-in of the well platform.
- 2 Dug-wells that have not sufficiently penetrated into the aquifer, i.e., they are not deep enough.

Research was undertaken to identify methods of rehabilitating failed dug-wells (Murugesu 1998). For dug-wells that suffered from sand ingress, an effort was made to make weep holes but it was difficult to make these weep holes with the tools available. The cast concrete rings were also liable to break in the process. A second method to rehabilitate dug-wells that suffered from sand ingress was to intersect horizontal filters between the rings. PVC (polyvinyl chloride) filters were used, because bamboo filters would not sustain the pressure. The cost of such rehabilitation was relatively high, around \$45.

For dug wells that had not penetrated deep enough, telescoping was attempted, i.e., using a smaller diameter. This method turned out to be risky—telescoping could unsettle the large rings, causing the entire

well to collapse. Telescoping with porous rings had more potential as this reduced the hydraulic head and made seepage through the rings easier, minimizing sand ingress from the bottom of the well.

Porous rings with a sharp 'cutting' edge on first indication hold promise for improved dug-well design. The sharp-edged ring facilitates the lowering of the rings. The advantages of porous rings are that wells of a smaller diameter can be made, thus, lowering costs.

The more promising option for areas with heavy clays and rocks in the substrata, however, is the use of a stone hammer, which allows the hand drilling of shallow tube wells in hard ground. The stone hammer consists of a heavy weight, which falls down a pipe, after being lifted by a lever. A stone hammer has the advantage of producing shallow tube wells at a lower cost and of greater reliability than dug-wells.

Stone hammer

The stone hammer technique is not known in the Terai region. It was developed in response to a need for low-cost well development in the 'hard layer' areas, close to the Himalayan foothills. The build-up of the hard layers is the result of past alluvial action, their thickness and number varies from place to place. The thick layers may consist of the following.

- Stone layers, characterized by the presence of boulders with a diameter of 20 cm or even more. The layers may be composed of gravel, sand, or stones, which makes their structure incoherent.
- Stone and clay layers, which are stone/gravel layers that are mixed with clay. The clay gives the layer a compact structure.

- Clay layers, which consist exclusively of hard, compact, clay.

In these hard layers the popular hand-sludge drilling methods do not work. Neither is it possible to penetrate the layers with a stone chisel. A stone chisel is a steel weight with a sharp point, which is allowed to fall freely from a height of 0.7 m onto the bottom of the well. The chisel will break the boulders, which can then be removed by the hand-sludge method. However, the chisel does not work because it is not only big boulders but the mixture of stones, gravel, and sand that makes it difficult to sink a well. Often, the chisel worsens the situation, by further compacting the soil. It is not always possible to use augers (an auger is a drill bit, attached to a pipe) in hard layers. The rotation of the auger fills the drill bit with soil particles and the drill bits must be repeatedly emptied. This method is not suitable for hard layers, because the bit cheeks bend without any progress being made.

The stone hammer method was developed as an alternative to the dug-well technology. The principle of the stone hammer is to break stones and compact layers with great force and remove the debris. For this to happen a galvanized iron pipe is lowered into the borehole. A hollow cylindrical shaped head is secured to bottom of this pipe. The hammer head breaks the stones, and the debris accumulates in side the 2 feet hollow pipe above the bit. To create the impact of the stone hammer, a weight of 80 kg is lowered into the pipe. The weight falls freely from a height of 0.7 m–1.0 m onto an iron floor, which has been welded into the pipe floor. This floor is situated at a slight distance from the ham-

mer head, in order to maximize the impact of the weight. By allowing the weight to fall repeatedly onto the floor, the bit is driven into the ground. Since the floor provides a water-tight closure to the pipe, the weight falls through an empty pipe, which increases the falling speed and allows the weight to exert a larger force on the bit.

After the falling motion, the weight is raised using a bamboo lever. The lever is connected to the weight with a rope (Figure 1).

The shape of the hammer head

The shape of the hammerhead holds the key to its effectiveness. Besides crushing the hard layer, the stone and gravel also need to be removed. This requires the bit

to be hollow with steel¹ teeth welded to its side, so that it can collect the crushed material and soil particles. The pipe and the hammerhead need to be raised repeatedly to remove the material collected in the bit. To minimize the chances of material falling out 0.6–0.8 m have to be hammered at a time, so that the soil and stone particles remain firmly compacted inside the bit.

For removal, just as with an auger, the pipe and the bit are raised slowly, while turning the pipe. After the pipe is removed, the well is washed with a sludge of cow dung to coat the wall of the well and prevent it from collapsing. The open bit is once again lowered and the next 0.6–0.75 m is hammered.

Where the hard layers are composed of loose strata with unconsolidated boulders, chances are that the well wall will collapse partially each time the bit is raised. This requires the bit to taper off so that the cow dung slurry reaches the lowest point in the well and the wall is plastered when the bit is raised, while rotating slowly.

The ideal bit (Figure 2) then has the following components.

- An open pipe 0.6–0.7 m long and 10 cm in diameter to collect the debris.
- Steel teeth welded to the open pipe and tilted inward to guide the debris into the open pipe and reduce the ground pressure around the hammer head, making it easier to lift the hammer head.
- A smooth outer surface, which allows the plastering of the well wall in the unconsolidated strata by turning the hammer head.

During tests it was found that a hammering speed of 0.3–0.6 m/hour could be

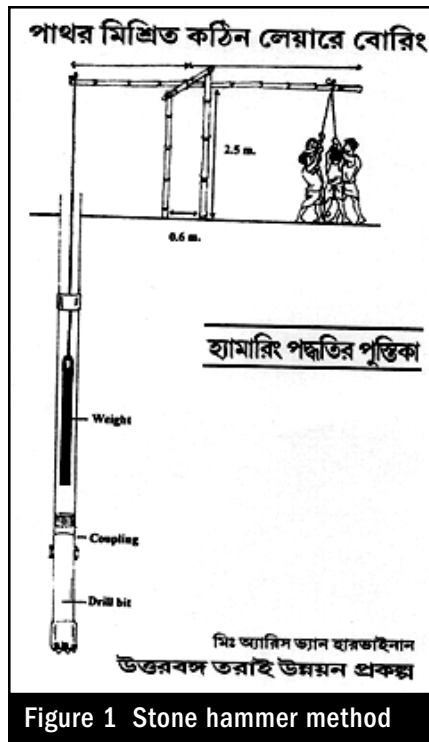

Figure 1 Stone hammer method

¹ The teeth of the stone hammer are made of car-spring steel to enhance the durability of the head.



Figure 2 Hammer head or bit



Figure 3 Back and forth movement of pipes

achieved (excluding the time required for lifting and cleaning the stone hammer) with progress in the clay layers being slower than that in the stone layers.

Shock-breakers

Recently shock-breakers have been used on the stone hammer to reduce pressure on the couplings, to increase the hammering impact and make lifting easier.

Raising the hammer head

Raising the hammerhead is as important as the hammering itself. Being able to raise the pipe and head quickly saves time and, partly, determines the success of the operation. Particularly in compact clay layers, raising the pipe can be cumbersome.

The most straightforward method to raise the hammer head is to secure a chain to the pipe, which is connected to the lever. By exercising force on the arm, an attempt is made to lift the pipe. At the same time the pipe is moved back and forth (see Figure 3).

Where this does not work, an alternative method has been developed to lift the pipe. This method uses a block that is placed inside the pipe. The weight is lifted repeatedly against the block and the resulting vibrations free the pipe from the ground. To use this method the hammer is first lowered into the pipe. At approximately 1 m above this hammer, a 0.6 m long, 5-cm diameter pipe section is placed inside the drill pipe. The 5-cm diameter pipe section is widened at the bottom to fit the width of the drill pipe. When sand is poured into the drill pipe, it will accumulate behind the thickened part of the pipe

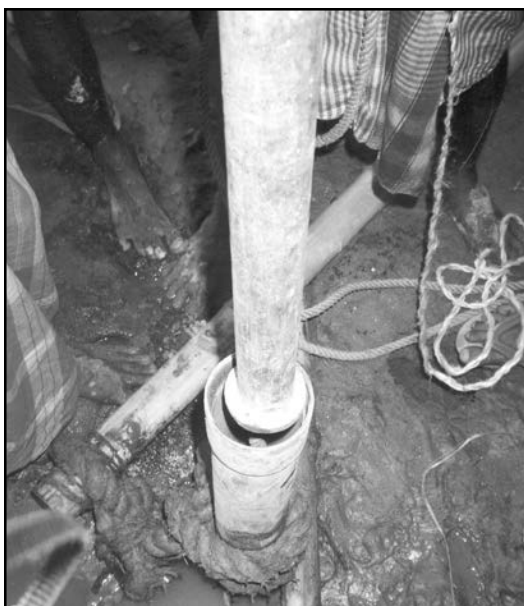

Figure 4 Lowering the blocking pipe for extracting the drill pipes by reverse hammering

section and the space between the pipe section, filling the drill pipe with sand. The rope connecting the weight to the lever is led through the 5-cm diameter section. When the weight is raised, it will hammer against the pipe section, which will become wedged in by the surrounding sand. The hammering against the block continues until the bit with the well pipe rises (Figure 4).

The stone hammer method

The stone hammer method consists of the following steps.

- 1 The hand-sludge method is used to start with and once the hard layer has been reached, the stone hammer is used.
- 2 The hammer head is connected to the pipe section with the floor. This pipe is connected to the other drill pipes used while working by the hand-sludge method until the correct depth is reached.

Table 1 Costs of the stone hammer kit

Item	Cost (Rs)
Weight (80 kg)	4000
Pipe with floor and coupling for the hammer head	1000
Hammer head	1500
Rope (25 meters)	1875
Lift pipe section/ block	250
Bamboo lever	250
Total	8875

- 3 The weight is then lowered into the pipe. Hammering takes place until the bit is filled with debris. In loose rocky strata, hammering is continued for a longer time in order to compact the debris.
- 4 Cow dung sludge, used to stabilize the well walls, is poured into the opening between pipe and well.
- 5 The weight is removed and the pipe with the hammer head is lifted with a rotating motion.
- 6 The debris is removed from the hammer head and the hammer head is once again lowered.
- 7 In loose soils it may be necessary to apply the hand-sludge method after every hammering phase in order to stabilize the well walls.

References

- Institution of Engineers. 1996.
Performance of dug wells
 Institute of Engineers, Jalpaiguri Consultancy Cell
- Murugesu S. 1998
Possibilities for dug well improvement
 North Bengal Terai Development Project
 [un published]

Conveyance: alternative routes

Conveyance losses – in the Terai and elsewhere – in private groundwater irrigation systems are often considerable. Unlike surface irrigation efficiencies, water losses from groundwater irrigation systems have not been extensively studied, yet in many cases they may exceed the losses from gravity water courses. Water pumped from shallow tube wells or pump dug wells is typically conveyed through makeshift earthen field canals, often undersized and hence with particularly high losses (Figure 1). Measurements in the northern West Bengal Terai show that in under-dimensioned earthen canals losses may run up to 53% per 100 m. But even when there is no overtopping, conveyance losses are considerable. Conveyance losses fall into two categories.

1 *Steady-state losses* that result from seepage from the porous earthen channels. In small-scale lift irrigation, where flows are usually between 6–15 litres, steady-state losses can take up a considerable portion of the flow. In established



Figure 1 Earthen channel

earthen channels in northern West Bengal they were measured at 6% per 100 m of the flow.

2 *Transient or start-up losses* that are related to the wetting of the dry perimeter of an earthen channel. Each time irrigation water is applied it will take time and water, before the channel starts to flow. In small-scale lift irrigation, water is usually applied frequently, but for a short duration. Obviously, transient losses depend on the duration and number of watering applications. For instance where 30 water applications of 2.1 hours each are made annually, transient losses have been measured at 8.4%–10% of the flow per 100 m. In intermittent groundwater irrigation, transient losses are therefore much higher than in a constant flow situation, which is characteristic of surface irrigation.

The combined transient and steady state losses are typically at least 15% per 100 m. These losses translate into extra pumping time and with it, extra pumping costs.

The construction of distribution networks has often been part of publicly funded groundwater irrigation systems to reduce high conveyance losses in groundwater irrigation. Sutherland (1999) has documented the systems most commonly used in South Asian public systems—lined channels or buried pipe systems. Of the two, buried pipes systems require particularly large capital outlays,

though this is partly compensated by the fact that they do not use land.¹ Lined canals – of all varieties – are relatively less costly, but even here the costs of the distribution network may be a multiple of the investment in the lift system, particularly for low-lift schemes.

By contrast, in privately operated lift irrigation systems in the Terai, it is uncommon to find similar substantial investments being made in conveyance systems. If investments are made, they are low cost. This chapter describes two promising conveyance techniques for private shallow tube wells. One increasingly popular technique uses lay-flat hoses and the other which is newly developed, involves soil–cement channels.

Lay-flat hoses: an unassuming revolution in micro-irrigation

In the last ten years lay-flat tubes have become a popular means of conveying water from the numerous shallow tube wells in the Terai belt of northern Uttar Pradesh, northern Bihar, and Northern West Bengal. An estimated 500 000 m of lay-flat hoses are sold in the three districts of North Bengal annually. In many areas a rental market has developed, where a typical 100 m section is rented out for Rs 5 per hour. This rapid spread of lay-flat hoses in the Terai mirrors that which occurred in northern China during the 1980s. Strangely enough though, there are also major areas where this type of micro-irrigation is not known at all.

The lay-flat hoses have a variety of advantages. Their water loss is close to zero, which is important for intermittent groundwater irrigation. The tubes also help avoid right-of-way problems and farmers can defeat gravity and irrigate higher lands. The usual length of lay-flat hoses is 100–300 m. Beyond this range the backpressure on the pumps is too large to handle. The two most popular tubes are the polyethylene and PVC (polyvinyl chloride) tubes. Other heavy-duty tubes are available, but as their prices are considerably higher, they are not commonly used.

Polyethylene tubes

The most popular tubes are the low-density polyethylene lay-flat hoses (Figure 2). Depending on their diameter they weigh

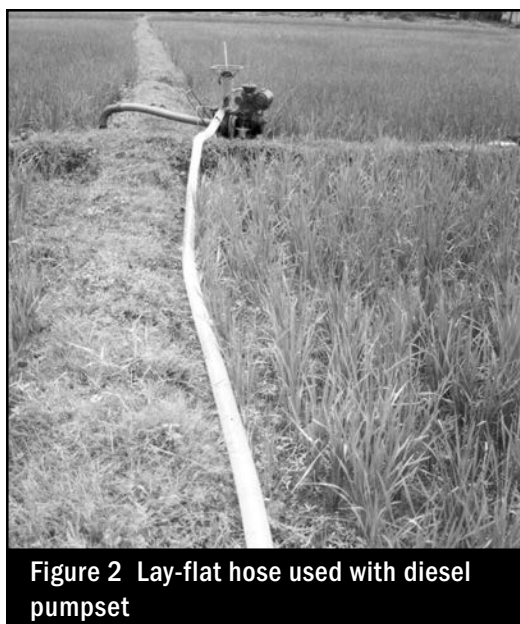

Figure 2 Lay-flat hose used with diesel pumpset

¹ In river lift systems in northern West Bengal the effectiveness of the buried pipelines was enhanced by using lay-flat hoses on the spouts of the water transmission systems. The design of the spout head had to be adjusted to a round outlet to make this possible.

between 8.5 g (65-mm diameter) to 16 kg (100-mm diameter) per 100 m. The 100-mm diameter tube is the most popular variety, as even 300 m of this tube is portable at 48 kg and requires little storage space.

The cost of a 100-mm lay-flat hose ranges between Rs 6.8/m (65-mm diameter) to Rs 14.4 (100-mm diameter).² Usually, the polyethylene tubes last one irrigation season, as sunlight and movement of water make them brittle and easily punctured. The tubes are made of recycled scrap, but can be resold as scrap too, at approximately 25% of their original price.

PVC tubes

PVC tubes are more durable, but also more expensive and heavier, and, as a result, less popular. PVC tubes cost Rs 12.8/m for a 65-mm diameter tube and Rs 33/m for a 100-mm diameter tube. Their scrap value is 30% of their original price. A 300 m length of a 100-mm diameter PVC tube weighs 87 kg.

The drawback of these tubes is that, in comparison to open channels, they increase the delivery head of the pump. The result is a higher consumption of diesel per unit volume of water lifted. The attachment of 100 m of a polyethylene tube of 100-mm diameter to the delivery pipe of a pump set (most delivery pipes have a diameter of 65 to 80 mm) requires 11% more diesel per cubic centimetre of water lifted. However, this is more than compensated by a reduction in the hours of pumping, as water losses even in well-prepared channels are 15% per 100 m.

Yet when 80-mm diameter tubes are used on the same delivery pipes, the

increase in delivery head exceeds the gains in conveyance efficiency. Diesel consumption shoots up by 48% for a 100-m tube. As a result, the 80-mm diameter hoses are less popular. They tend to be preferred for long distance water transport (300 m), as farmers believe that the larger jet through the narrow hose ensures that the end of the pipeline is reached.

Small diameter (60-mm) lay-flat hoses have also become popular on hand pumps. This is not surprising, because the conveyance losses from the small hand tube well discharges (0.5 to 1 litre) are proportionally much larger than the losses from shallow tube well flows. In response, hand tube well users were already practising indigenous micro-irrigation, in particular the use of plates to scoop up water from a small ditch in the field and sprinkle it over the crops. The small diameter lay-flat hoses, attached to the spout with a short bamboo section or bottomless metal cup, will not be used that intensively and will last long. Also, unlike with diesel pump sets, no additional head is created, which would increase the effort in pumping.

Soil-cement channels: the alternative route

A second alternative to makeshift earthen channels is improved low cost channels (Figure 3). With shallow tube wells and dug wells generally being used for 400 hours in a season at the most, it is obvious that open brick-lined or concrete channels that cost upwards of Rs 200 would never be an option for shallow tube well owners. With 15% losses

² Exchange rate used is Rs 42 to 1\$.



Figure 3 Soil-cement channel

over 100 m and a diesel price of Rs 12/litre, annual fuel savings of Rs 720 would not justify the investment in brick-lined or concrete channels, even taking into consideration other benefits such as the possibility of extending the command area.

A series of trials were undertaken to come to an alternative low-cost technology that would reduce water losses. Several makes of channels were field-tested by farmers for an entire irrigation season. These included soil–dung channels, lime–brick–dust channels, lime–sand channels, soil–cement channels, clay–tile channels, and plastic sheeting. The farmer’s assessment of the different types of channels one year after their construction is given in Box 1.

The low-cost technology that found most favour involved the soil–cement channels. This technology is uncomplicated and farmers themselves, with the help of local mechanics, can construct the channels. The

earthen channel is first shaped in the right dimensions and adequately compacted. Subsequently a 50-mm-thick layer of plaster is applied. The preferred mixture for plastering is one unit of cement, one unit of soil, and four units of sand. Cement is the only input that has to come from outside. The sides of the channels are then covered with a layer of soil and grass turf to avoid damage to the otherwise brittle top of the channel. Box 2 describes the ideal specifications of the soil–cement channel.

In comparing soil–cement channels with earthen channels, farmers identified the following advantages.

- *Faster water flow to the land* As hardly any water infiltrates through the channel and the surface is very smooth. This saves a lot of time, with the advance time required for faraway plots being considerably shortened.
- *Reduced water loss* Related to the above, the considerable transient losses, at starting and closing time, have been reduced significantly. Further there is very little seepage and no overtopping. In soil–cement channels the steady-state water losses were measured at less than one per cent over 100 m.
- *Reduced fuel consumption and application time* Due to the reduction in water loss, the total application time is reduced and, consequently, fuel is saved. In the tests involving farmers, the application time for a typical plot of 0.15 ha was reduced from 4 hours to 3 hours.
- *Less labour required* In an earthen channel, two persons are involved during irrigation. One handles the water in the field and another walks up and down the channel to check the water flow. This second person is no longer required, which is a

Box 1 Test results of different types of low-cost channels

Soil–dung channels (mixture 3:2)

- Nothing of the original lining remained, it was completely washed away.
- Dung also has other uses, as manure and a fuel, which have higher priority.

Lime–brick–dust channels (mixture 1:4)

- Material is brittle like low quality bricks and, therefore, can easily be damaged.
- Some holes and quite a number of vertical cracks were observed.
- Proper curing time when making the mixture renders the construction process more cumbersome.
- All materials, i.e., brick-dust and lime have to come from outside.
- Lining absorbs water when in use, causing transient losses.

Lime–cement–brick–dust channels (mixture 1:1/2:4)

- The channels are stronger than only lime–brick–dust and show fewer cracks.
- The cost is relatively high and quality is found to be inferior to soil–cement.

Lime–sand channels (mixture 1:3)

- This material is quite porous, which might still cause some seepage.
- It has a very rough surface, impeding the flow of water.
- It looks reasonably strong, but is soft inside .

Clay tile channels

- Plain tiles and V-shaped roof tiles were tried, but both types were simply too fragile and too prone to theft, therefore the technique is not viable.
- Joints remain a weak part in the construction.

Plastic sheet channels

- If properly done, sufficient soil cover (1 foot) has to be provided, which results in an increased section and, therefore, more land occupation.

Soil–cement channel mixture 1:2:3 (cement:soil:sand)

- There are hardly any cracks or holes if the channel is constructed properly.
- The material is softer than the 1:1:4 mixture due to the large quantity of soil.

Soil–cement channel mixture 1:1:4 (cement:soil:sand)

- This mixture is found to be superior, more sand adds to the strength of the plastering, whereas soil takes care of the cohesion with the underlying soil.
- At Rs 50–60 per metre, the technique is relatively cost-effective.

major benefit if there is a shortage of labour during the agricultural season. Moreover, less labour is required to prepare the channel at the start of the irrigation season, i.e. for cutting the grass, repairing the bunds, and shaping it to the proper dimensions. In soil–cement chan-

nels maintenance is still necessary, but the time required is much less.

- *No water-logging near the channel* Severe leakage, overflow and breaches in earthen channels result in crop losses in the strip of land along the sides of earthen channels.

Box 2 Technical aspects of soil-cement channels

Mixture

Different mixtures can be used. The quality of channels constructed with a mixture of 1:1:4 (cement:soil:sand) is found to be superior over the mixture 1:2:3. The plastering becomes stronger and more rigid because of the higher sand content, while the soil coheres with the underlying soil. If more sand is used, the strength might increase further, but contact with the underlying soil might be lost.

A trial was also carried out with a 1:4:2 mixture (cement:stone-dust:sand). Stone dust is available at places where stones/boulders are crushed into smaller pieces for road construction, for example. This mixture was found to be stronger than the 1:1:4 soil-cement mixture. The use of stone dust appears to add to the strength, but the problem is its availability, as crushing machines are only available at a few places. The dust will have to be carried from a long distance in many cases. The use of stone dust is only recommended where it is easily available.

Compaction

Field trials clearly indicate that compaction of the channel's earth is essential, even though it is time-consuming. Better results are obtained in channels that already have bunds. Without compaction, hollow patches appear below the plastering and the channel becomes weak. Also, horizontal cracks at the bottom of the channel (Figure 4) are due to improper compaction of the channel bottom. In cases where no proper existing bunds are present, earthen embankments can be made before the monsoon, in April and May, when the farmers have time. During the monsoon, the soil will settle due to the rain. After the rainy season, in October and November, the channels can be constructed (Figure 5).

Use of joints

Some vertical cracks are observed in the channel. These cracks occur mostly in the first month after construction. While most of the cracks are due to construction defects, the use of joints, i.e., artificial cracks, is likely to be an improvement, allowing for differential settlement and expansion. A joint could be made every

2 m and if possible, filled with tar to reduce leakage. An additional benefit of such joints is that when repairs are required a farmer can remove a complete 2 m segment. After applying the plaster, neat polishing with a mixture of water and cement for proper finishing will make the surface smooth and strong.

Preparation of mixture

The soil-cement lining is strong enough, but the mixture needs to be prepared properly. If the mixing of soil with the sand and cement is improper, then holes may appear. The solution is to dry the soil and sieve it before use.

Curing

Proper curing is important for strong lining. Proper curing essentially means that the concrete remains wet or moist for the first 7 days after application. This can be ensured by covering the fresh concrete with jute bags, which are regularly wetted.

Embankment

Field observations show that the channels survive properly only if the embankment is higher than the plastering height. In cases where this was not so, the top part started cracking and pieces fell down. The only way to protect the plastering is to provide 2 inches of earthen freeboard, strengthened with grass turf. Without grass, the bunds will remain fragile. This is an absolute must for a good channel.

Contd...

Box 2 Contd...

Dimensions

The dimensions of the channels are based on a bed slope of 1/1000, which means in reality, very flat terrain. However, at the time of construction the actual field slope is used, as channels are constructed in existing earthen channels, which already have a downward slope. In some cases, the bed slope is more and, therefore, theoretically the dimensions can be reduced, making it cheaper. The following standard dimensions are used for diesel pump sets with a discharge of 12 litres/second.

- 1 Bottom width (inside) : 0.20 m (8 inches)
- 2 Height of plastering (inside) : 0.20 m (8 inches)
- 3 Side slope (vertical:horizontal) : 1:0.5

The pressure in the channels is not because of water pressure, which is only 0.01–0.02 kg/cm², with water 6–8 inches deep. More crucial is the pressure put on the lining by humans and cattle (**Figure 6**). For this reason the bottom width of the channel is kept small, which discourages cattle and humans from walking in the channel.

Thickness

In the first round of trials a lining thickness of one inch was tried. As farmers and local mechanics constructed the channels, the work was done less precisely, resulting in thickness fluctuating from 0.5 to 1.5 inches. To improve the strength, an increase to 1.5 inches was recommended. This has proved to be good even after one year and so it is recommended even though it increases the cost.

- *Increased irrigated area* More land is being irrigated in some cases, as water is saved. Cropping patterns have become more intensive, too. Farmers reported that due to the construction of 100–200 m of channels, the irrigated area increased by 25%–50%.
- *Irrigation of upland areas possible* Upland areas can be irrigated by constructing a channel-in fill.

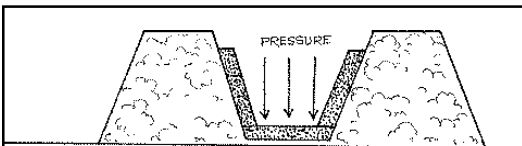

Channel bottom is pushed down and cracks occur at the joints.

Figure 4 Channel bottom is pushed down and cracks occur at the joints

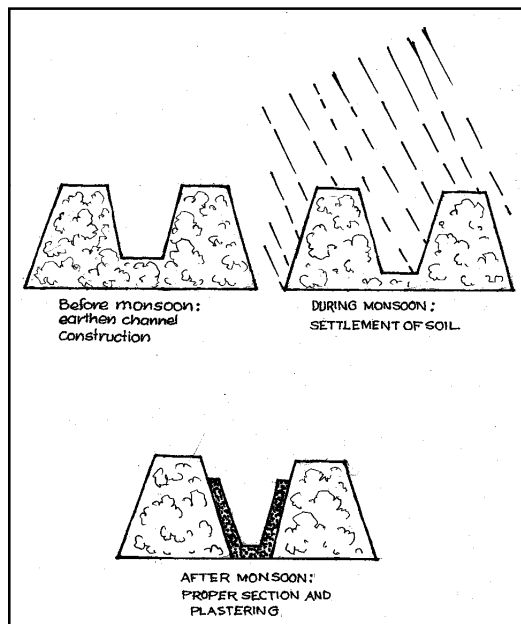

Figure 5 Impact of rainfall on construction

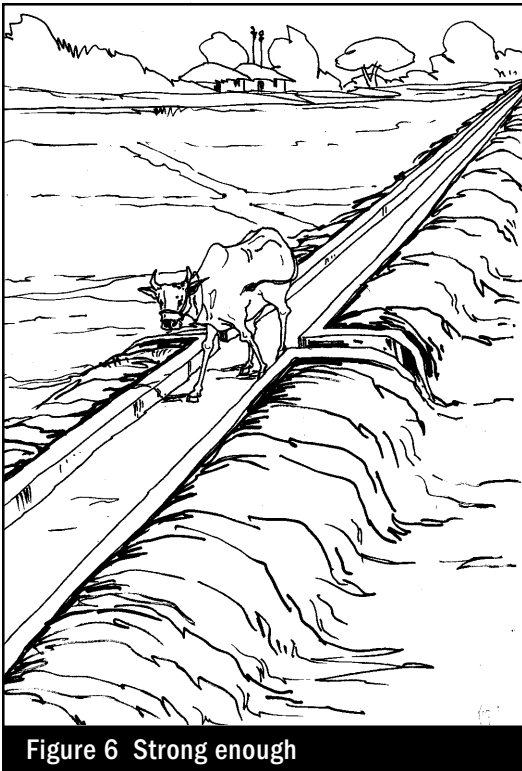

Figure 6 Strong enough

- Other benefits When ducks were kept on the farm, they remained near the house because they used the channel, saving the effort of getting them back in the evening. The channels were also used for washing clothes, for which earthen channels are not suitable.

Besides the advantages, a number of disadvantages from the soil-cement channels were also cited.

- Precision required in levelling channel bottom At the time of construction, the channel bottom has to be levelled properly and given a continuous downward slope. This is considered a tedious job.
- Not rat-proof The channels rest on soil. When rats remove the soil, the support

for the channel is also weakened and the channel may collapse if not maintained properly. High channels in lowlands are favourite hiding places for rats during the rainy season.

- Blocked sheet flow drainage During the intense monsoon season in northern West Bengal lateral run-off flow takes place. In some cases, the permanent channel may block the flow causing the adjacent plot to fill with water. However, this problem can be solved by putting bamboo drainage pipes below the channel (Figure 7).

In spite of these disadvantages, many farmers found that at Rs 58/m for a 20 cm (bottom width) × 20 cm (plastering height) section – sufficient to carry a discharge of 10–12 litres/second – cement channels were worth the investment. Being a new technology, in northern West Bengal soil-cement channels were introduced with a subsidy of 50%. Farmers would construct channels with the help of a local mechanic who had first undergone a one-day training in the soil-cement technique. If the channel was completed according to specifications, the farmer would be reimbursed for his share of the work. This modality was meant to introduce the new technique while simultaneously building up local capacity. Each year 5000

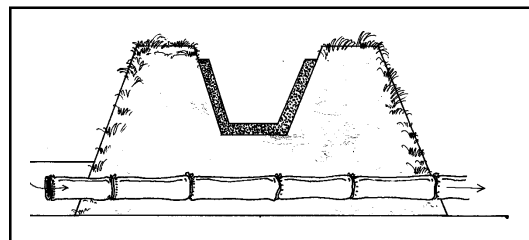

Figure 7 Use of bamboo pipes for drainage

to 10 000 m of channels were constructed in this manner.

Farmer's priorities

At present the lay-flat hoses are far more popular than soil-cement channels. This is likely to remain so, *inter alia*, because it is a conveyance technology that is sold off the shelf.

Lay-flat hoses have a number of advantages over permanent soil-cement channels. First, they do not occupy land and permission from neighbouring landowners to traverse land is easily given. Moreover, they can be laid out in any direction and from any point. One tube may, hence, serve an entire command area. Second, lay-flat hoses can cross obstacles such as roads and water can be pumped to higher land. Thirdly, their capital investment is low at Rs 14/m for a polyethylene pipe, which is a quarter of the cost of a soil-cement channel. This low capital cost however partly disappears because of the extra pumping costs of at least 11%.

Owners of soil-cement channels on the other hand were quite content and evaluated the soil-cement channels positively in comparison with the lay-flat hoses. One advantage cited was their long life. While the soil-cement channels are estimated to have

a life of 4–5 years, the polyethylene pipes usually last a year only. Therefore, over a 5-year period the costs are similar. A second advantage is that the use of a soil-cement channel requires little effort apart from cleaning the channel in the beginning of the season, whereas a lay-flat hose needs to be laid out carefully every time the field is irrigated and removed afterwards. Besides, during irrigation vigilance is required to ensure that there are no leaks or blockage in the tube. Finally, conveyance through soil-cement channels does not require any extra pumping costs.

It appears then, that both techniques have their own niche for the short-stretch conveyance typical in shallow tube well irrigation. Neither technique is likely to be used over long distances. With lay-flat hoses there is a maximum distance over which their use remains practical. In case of soil-cement channels, it makes more sense to make a second low-cost shallow tube well rather than extend the channel network too far.

Reference

Sutherland D. 1999

Sustainable groundwater irrigation technology management within and between the public and private sectors

Silsoe: Cranfield University

Dissemination: making it work

The best technology is not always with us

The best technology is not always with us. There are examples from bicycle rickshaws to video recorders where a better technology has not made it to become the consumer standard. Dissemination is in many ways the hardest part of participatory technology development. Innovations do not necessarily disseminate on their own. The challenge is to reach a critical mass whereby the new technology is sufficiently familiar and an entire service sector is in place—several improvements never made it that far and though superior, they have been forgotten. There is resistance to innovation dissemination in manufacturing, delivery, and consumer systems, as detailed below.

Manufacturing systems

- *Limited R&D (research and development) capacity*
- *Long supply lines* Little consumer feedback to manufacturer.

Delivery systems

- *Ready to use* The new technology does not come as an off-the-shelf product.
- *No specialization* The product is one of a large range of products sold.
- *Artificial barriers to entry* A market dominated by official quality standards, for instance.

- *Complexity* Any new technology places heavy demands on knowledge of retailers and distributors.
- *Delivery system* The retailers and distributors are not well-organized and are undercapitalized. There is no mechanism to finance promotion of new ideas.

Consumer system

- *Relevance* The new technology though profitable affects only a small part of the operating budget.
- *Perceptions* There is a strong belief in proven technology.
- *Poverty* There is little capacity to experiment.

This chapter documents lessons learned in promoting new shallow groundwater irrigation technologies particularly fuel efficient pump sets. The second section discusses innovations in well and channel technology.

Promoting fuel efficient pump sets

Convincing users

The improvements in fuel efficiency described in chapter 2 were so significant that it seemed as if just spreading knowledge would convince users either to modify old pump sets or buy new and more efficient models. With diesel consumption down by

40%–50%, who could resist modification, particularly as the cost was low (Rs 400–500), compared to the savings. Yet, in the end conversion turned out to be more difficult and required more than only spreading knowledge.

A series of attempts was made to introduce the new pumpset technology—the drum cooling, reduced engine speed, and the priming pump replacing the foot valve. The first major effort was to provide farmers with training from government staff. For this, field mechanics, employed by the Department of Agriculture, were engaged. Their main task is usually to oversee mechanical work undertaken by the department. They had the right technical background and sufficient spare time in the off season. It seemed a good idea. The mechanics were introduced to the pump modifications and trained to organize demonstrations. They were also to identify farmers with pump sets and village level mechanics, *mistri*, who could carry out modifications.

The training raised interest and curiosity. Yet after 17 demonstrations, only 3 pump sets had been modified and no *mistri* was keen on modifying pumpsets as a business. Subsequent analysis revealed that

- the government mechanics themselves were not fully convinced of the technology;
- the demonstrations and follow-up were not organized professionally;
- the government mechanics lacked the trust of the local mechanics, who feared the pump would burst; and
- the farmers did not feel strongly about the need for modification.

Government mechanics were also not readily available so, the effort was abandoned. It was replaced by demonstrations organized by a specially appointed trainer, who was familiar with the modification to the pumpset (Figure 1). He worked closely with field staff of the Department of Agriculture. The field staff would identify where the demonstration would be organized with a farmer who owned a pump.



Figure 1 Pump modification demonstration

The involvement of the field staff had an encouraging impact. Before the demonstration a publicity drive ensured the participation of a large number of farmers. Demonstrations consisted of

- brief discussions about the need for fuel saving,
- discussions about the technical processes involved in modifications,
- live demonstrations,
- sale of modification kits on the spot, and
- post-demonstration discussions and follow-up.

The post-demonstration activity involved discussions with the farmers about the demonstration and steps involved in

the modification. Farmers were also requested to indicate whether they were interested in the modification and were required to fill up a form stating their commitment. A total of 133 demonstrations were organized in which more than 3000 farmers participated. About 10% of the farmers indicated they were interested in the modification. The trainer kept track of the commitments by making either a return visit or writing a return post card, enquiring about the follow-up action. The post cards yielded a positive response and several farmers who had earlier indicated an interest in the modification renewed their promise. Others wrote back saying they could not make the changes, giving family commitments or crop failures as reasons.

Finally, 283 pumpsets were converted, a significantly higher number than after the first training effort. Yet the output was still far from encouraging considering the effort put into preparations, demonstrations, and follow-up.

Meanwhile, several pump dealers evinced an interest in the modification and attended some demonstrations. They also sent their mechanics for training.

However, they withdrew from the program when they learnt that their pumps would not be purchased by the government.

Contact with some local mechanics continued through intensive training-cum-demonstration but the spin-off in terms of actual modifications was not so encouraging. Field visits confirmed that even farmers who had modified the sets were cautious in using them. A headcount showed that about 60% of the modified pumps supplied by a government programme were unused. The boiling water in the drums suggested something going out of control. Refilling

them required extra care because the drums were made of sheet iron and prone to corrosion. To increase the acceptability of fuel efficiency improvements, drum cooling was dropped and replaced by a flow restrictor which guaranteed that only a minimal amount of water would be circulated to cool the engine. This was also far more convenient to use.

Efforts at promotion also underwent serious rethinking. It became obvious that the *mistris* were the most effective channel because they had the confidence of the clients and could persuade them to overcome some persistent misconceptions about pumpsets (Box 1). They could earn money by modifying existing pumpsets and servicing new ones. Moreover, they could introduce other new technologies such as the bamboo filter (Chapter 4) and the stone hammer (Chapter 5). Some of them closely liaised with dealers, whereas others did not. Among the latter group there was a growing interest in promoting the different new techniques. After a training programme, a number of these village-level mechanics agreed, that, apart from selling the new technology, they would also gain if they provided their services as a group. This would allow them to gain recognition, learn from each other, undertake common promotion, and become collectively engaged in government contracts.

Five *mistri* cooperatives established themselves in 1999. They had on average

Box 1 Pumpset beliefs

- If a pump is starved of diesel it will die
- A heavy pump is a strong pump
- If a pumpset becomes very hot it will burst.

15 members, a mixture of seasoned mechanics and apprentices. They took a small loan to set up a small common shop and stock spare parts. In support of their sales the *mistri* cooperatives – using their own resources – organized training and demonstration programmes on pump modification, improved bamboo filter wells, stone hammering, and the construction of soil-cement channels. The first 5 groups managed in the first-year-and-a-half of their existence to modify 418 pumpsets, sell 59 modified sets, and develop 1056 tube well borings using the improved bamboo filter technique (Chapter 4), approximately half of the borings were made by them. Some of the groups also engaged themselves in the business of well washing and servicing the new fuel-efficient pumpsets provided as a part of government programmes.

The *mistri* route proved to be the most effective way of promoting efficiency improvements and treadle pumps (Chapter 8). In 2001, the number of *mistri* groups increased from 5 to 13 with several of the new groups enthused by existing ones. Setting up the new groups, however, was difficult where these mechanics came from other areas, migrating for a number of weeks to dig wells. A comparison of the *mistri* cooperatives and the training efforts showed that promoting fuel efficiency improvements was not just a matter of disseminating knowledge, but also of developing confidence in the new techniques and setting up a service sector that could sustain it.

Convincing manufacturers

The structure of the diesel pumpset manufacturing sector is such that innovations

are not necessarily natural. A substantial number of pumpsets is provided with a subsidy in the shape of cost reductions or low interest loans, or they are given away free. Precise figures are not available, but probably as much as 75% of the turnover in eastern states such as Bihar and Assam come with this tag. In West Bengal, where the field work was carried out, distributors estimate that around 25% of the market is subsidized. Since subsidies reduce the customer's check on quality it is essential that the state establish norms and standards. The most comprehensive and widespread of these is the IS (Indian Standard). While, in principle, standards are useful, it is not uncommon for industry to influence specifications to its advantage. One of India's largest manufacturers of diesel pump sets admitted that it was able to defend the market share of slightly upmarket models in this manner. There are several other barriers to innovation within the pumpset manufacturing sector, some are: limited R&D capacity, a long distance between manufacturer and the customer insulating feedback, and the importance of brand reputation.

A special effort was made to familiarize manufacturers with fuel-saving modifications and to encourage them to develop more efficient models. Visits to several main pumpset producers, resulted in only a polite interest. Organizations such as the Indian Pump Manufacturers Association and the West Bengal Pumpset Distributors Association were visited too, but they were only slightly interested in delivering products of a better quality. Their preoccupation was with government procurement procedures and industry standards.

However, a workshop on pumpset fuel efficiency resulted in one promising contact with a medium-sized manufacturer, BSA (Balban Singh Agriculture) in Agra, which was keen to develop an adjusted model in the low hp (horsepower) range (2.5 hp). In 1998, it prepared a prototype on the basis of the work in northern West Bengal, which was tested successfully passing both endurance and fuel consumption trials. When a government tender for pumpsets for 300 so-called multifilter point shallow tube wells (see Box 2) came up in 1999 in Northern West Bengal, the specifications were such that only the new improved fuel-efficient 2.5 hp model would qualify. The model was fuel efficient and considerably lighter.

Box 2 Multifilter point shallow tube wells

The 2.5 horsepower pump sets were introduced in a programme of 'multifilter point shallow tube wells' as a part of which groups of four small farmers constructed tube wells at their own cost—the choice of type of boring was their own. The lightweight pump sets, easily carried from one tube well to another, were provided free.

This programme replaced an earlier one in which similar groups shared a single filter point shallow tube well. They contributed 25% in cash to the development of the boring and the pumpset. This arrangement depended on one resourceful farmer, who would pay the cost contribution in time for annual programme targets to be met, have the tube well on his land and the other owners in the group would be secondary. The multifilter point formula instead ensured that everyone had direct access—even poor group members being able to construct low cost bamboo boring (Chapter 4).

Not unexpectedly, the new specifications created a stir with dealers of several major brands discovering they could not contend. They lobbied hard to have the tender cancelled and even managed to do so, but a few months later it was revived with more or less similar specifications. Opposition from the dealers again gathered force. Word was sent out that the current tender was only the pilot for a very large programme with a target of 4000–5000 fuel-efficient multifilter point shallow tube wells. Cancelling the current 'pilot' tender would jeopardize the follow-up programme. To level the playing field, all manufacturers were invited to a workshop. The dealers believed the white lie.

The workshop in which the fuel efficiency improvements were demonstrated was a success. It was attended by technical managers from the manufacturing companies rather than the sales personnel. Convinced of the improvements, the technical managers signed a memorandum, expressing their appreciation of the improvements to the pumpset's design. In the tender that followed, another manufacturer qualified with an efficiency-improved low hp-model and, not long after, 2 more manufacturers started to produce the fuel efficient models. The battle was won on the manufacturers turf—that of tender specifications. Being able to present an improved model was of little significance.

A number of other government programmes adopted the new design, which generated more interest. With more lightweight fuel efficient pumpsets available, popular demand increased too. One of the 4 manufacturers dropped out, unable to compete but the other three (BSA, Bharat, and Field Marshal) generated an independent

market. Bharat managed to sell 1500 pumpsets in its first year in Bihar, showing that the new models were taking root and generating a demand for themselves.

Bringing users and manufacturers together

One of the problems noted is that the chain between manufacturers and pump users is so long that there is little feedback on user needs and preferences. At the same time, in introducing a new technology substantial new understanding needs to be generated – among dealers, mechanics and prospective customers.

To bring together the different players on one platform, ‘pump fairs (*melas*) cum clinics’ were organized in each district where, with government support, the new pump sets were popularized. The organization of the pump fair was done by the cooperative of mechanics, who were given modest financial support to announce the *melas*.

What the fair achieved was to explain the benefits and techniques of the different fuel efficiency modifications, bring pump owners in contact with experienced mechanics, solve some of the technical problems on the spot, and generate feedback and interaction between users and manufacturers on main operational problems. During the fair also, new low-cost adjustments were identified. In several places, farmer-users had used small bamboo splits to work effectively as flow restrictors.

Technical sessions were organized in a festive mode and problematic pump sets were repaired and serviced free of charge. A quiz was organized to test the farmers’ understanding of pump-set handling as well as financial matters. The first prize was

a pump set donated by the manufacturers. There was a crop exhibition and the pump-set manufacturers and their dealers sold pumps on the day, providing special discounts. The fair being opened by local dignitaries also helped getting support for the new technology at this level.

The total costs of three fairs and their preparation amounted to Rs 86 000 (\$2000), part of it sponsored by the manufacturers. As they drew 15 000 farmers, these were extremely cost-effective learning events.



Figure 2 Pump *mela* bringing users and manufacturers together

Lessons learned

Contrary to common belief it appears that demand is not generated so much as an objective need but more as a response to what is being offered. The lesson from promoting fuel efficient pumpsets in northern West Bengal was that consumer training was not sufficient and, probably, not even useful. Besides their apprehensions, it was unrealistic to expect farmers to base a decision on only a demonstration and that too, by an outsider unable to win over the local mechanics, in this case. Perhaps the most precious asset of a northern West

Bengal farmer and his largest capital item is a pumpset. The first lesson learned was the importance of convincing and engaging the delivery sector in the promotion of the new technology. Pumpset promotion started to move only when the self-organized *mistri* groups were in the business. At that point, promotion perpetuated itself because better service and a better product meant improved incomes.

Engaging the delivery sector is not easy. One major constraint was the non-availability of appropriate sales points for treadle pumps in some areas. Some areas were covered largely by an itinerant *mistri*, making it hard to make inroads into the pumpset sector. The absence of a proper commercial distribution and maintenance infrastructure makes the promotion of new technologies by the NGOs (non-governmental organizations) necessary (smokeless stoves in Pakistan, low-cost drip systems in Andhra Pradesh, treadle pumps in Bihar). This may sometimes be the only choice and may even help to 'prime the pump', but the long-term prospects of this strategy are risky, if not dubious.

An equally important issue is the way the delivery sector is organized and structured. To assume that the quality of services is the overriding criterion is naïve. Manufacturers protect their market share through specifications and standards and each *mistri* is loyal to certain dealers and brands. This is particularly true for a relatively costly pumpset where government procurement, brand reputation, and the availability of spare parts is important and there is an inertia in changing over to a new technology. In an official procurement, changing specifications can break the deadlock, as the case described in this chapter

shows, but it is seldom done. Even in large programmes, funded nationally or internationally, specifications are laid out blindly without considering the subtle social impacts of different technologies or the opportunities of setting a new standard.

Specifications also obstruct in another manner as was demonstrated rather dramatically, with the well technology. The polyvinyl chloride well pipe with bamboo filter (Chapter 4) was found better than the GI (galvanized iron) or brass options. These options cost 10–15 times more and were not necessarily longer-lived, because of the larger risk of clogging. Yet, it is hard to capture standard specifications for a bamboo filter and the wastage caused by this is enormous.

At the root of the matter lies the failure to understand what technology is functional, what clicks and what does not. Standards and specifications often assume that things should be fail-proof and that the material should be durable. However, experience with the clogged GI filters showed that material may be durable even though the wells are not. The bamboo filters were inexpensive and performed well—they could be replaced at a low cost. The lifetime of lay-flat hoses (Chapter 6) may not be more than a year, but they are cheap enough to buy and are more widely used than any other water-saving conveyance technique. A similar breakthrough in drip systems is now reported from Maharashtra, where local entrepreneurs have developed ultra low-cost systems at one-fifth the price of the cheapest drip systems, developed and promoted by the NGOs. The system does not last more than a season, but even that is cheap considering the opportunity cost of scarce capital for poor families. There is need to rethink the concept of infinite durability.

Rural marketing: making it sell

The domestic 'market' – what is it?

This chapter analyses the introduction of treadle pumps through the private sector in northern West Bengal. This analysis is of interest for two reasons. First, a number of studies project that substantial investment in water resource development will be required in the coming decades to keep up with the demand for water services. With government budgets under pressure, much is expected of domestic investments. The private sector is presented as a vibrant alternative to the distorted and unsustainable system of public subsidies. Global Water Partnership (2000) for instance, estimates that 39% (up from the current 19%) of the necessary increased water investments will have to come from domestic markets. But, what precisely are these markets? How should they be supported? How do we make them work, particularly if they deliver a good that is of particular benefit to farmers with smallholdings and low real wages? This raises the second question that this chapter intends to address. It aims to do so by describing five seasons of the promotion of irrigation treadle pump in three districts (Cooch Behar, Jalpaiguri, and Siliguri) in northern West Bengal.

Before 1995, treadle pumps were hardly known in northern West Bengal, except in a number of border villages, where treadle

pumps smuggled in from Bangladesh had become popular. In one of these areas there were even two small workshops manufacturing small quantities of treadle pumps (50–200/year). Given the large popularity of treadle pumps in Bangladesh, it was surprising that in northern West Bengal there was a general lack of familiarity, an indication that innovations do not necessarily spread. As in Bangladesh, the majority of the farmers in northern West Bengal have land holdings under half a hectare. Daily wages do not normally exceed one dollar. The outlook for this manually-operated irrigation technology – far superior to other manual lift systems in vogue – appeared bright. The treadle pumps consist of two cylinders with moving pistons, operated by a person, who steadily moves the two pedals attached to the pistons. Depending on the model and the lift, 'treadling' yields 1–1.5 litres/second, sufficient in northern West Bengal to irrigate 0.2 ha of commercial vegetable crops. Entrance costs are low. The cost of a treadle pump – including the development of a bamboo well using local techniques – is typically around \$25¹ an investment that can, under normal circumstances, be earned back within a season. Moreover, water tables in large parts of northern West Bengal are high, mostly falling within the maximum suction range of treadle pumps (8 m). Northern West Bengal is not greatly served by diesel pump sets,

¹ The exchange value of the US dollar during the period described in this chapter ranged between Rs 38–46.

a technology with which treadle pumps may in fact even compete.²

Finding the right product

The promotion of treadle pumps in northern West Bengal was undertaken by IDE (International Development Enterprises), a NGO (non-governmental organization), committed to ‘fulfil the ambitions of marginalized farmers through marketing’. The choice was made to promote the treadle pumps in a non-subsidized fashion through the private sector, hoping that the mechanism would in the end be self-perpetuating, driven by profit motives, once a network of manufacturers and dealers was in place and the ‘product’ became familiar.

The promotion of treadle pumps started with a consumer survey to assess whether there was a demand for the treadle pump and, if there was, then what type of treadle pump the rural customers in northern West Bengal preferred. The choice was between two models. The first had pistons of diameter 5-inch and pedals of mild steel. The price off-the-shelf was Rs 1100. The second model had bamboo pedals and pistons of diameter 3.5-inch. Due to the smaller pistons, the discharge was lower, although the pump was easier to work on. This ‘bamboo’ treadle pump was similar to the model that was most popular in Bangladesh. Its cost was significantly below that of the mild steel version, Rs 225 compared to Rs 1100.

The first part of the consumer survey was a controlled test of the energy requirements of treadle pumps and their discharge. This test showed that the 5-inch diameter

model had a considerable advantage in terms of water output, particularly at very shallow depths. The second part of the consumer survey was the installation of 52 test treadle pumps of two different makes. The test installations were clustered to allow new users to judge for themselves. The first feedback was disappointing—whatever the model, mild steel or bamboo, the general response was that the treadle pump ‘did not work’ and was a non-starter. The pumps leaked profusely and did not hold water. Upon investigation the problem was found to be caused by a minor issue related to maintenance. The rubber check valves at the bottom of the cylinders became concave and started to leak because of incessant pounding by the pistons. The solution was simple and required only flipping over the check valves which would take 5 minutes. In the haste of installing the test pumps, this basic information had not been passed on, suggesting that the pump would not just sell on its own, and that some minimum technical information would need to be provided, while introducing the product.

After the check-valve problem was rectified, the test user’s experiences were collected. Where mild steel treadle pumps and bamboo treadle pumps were installed in the same village, the preference was clear—the sturdy mild steel pumps were preferred over the wobbly bamboo pumps. Just one cluster, where only bamboo treadle pumps were installed, reported very satisfied bamboo treadle pump users. Earlier controlled tests had hinted at a similar preference for the 5-inch mild steel treadle pump, as they yielded twice the discharge without exhausting the test person.

² In the end, in some – not all – parts of northern West Bengal treadle pumps appeared to be able to push out some diesel pump sets, particularly since the hiring charges for the heavy weight diesel pump sets included a transportation charge, which raised the effective costs per pumped hour for small holders considerably.

In retrospect, however it seems that, the consumer survey was flawed, as the test pumps were given free to first-time users. The litmus test came when the 5-inch treadle pumps were introduced to a border village already exposed to the smuggled bamboo treadle pumps. The first reaction was very positive. The new model was considered an improvement, but within a week the mild steel treadle pumps were returned. The reason was that at 17 kg they were far too heavy to carry to the fields. This one important parameter, portability, had not been considered in the customer survey with first-time users, the test having considered only price and water output, and omitted convenience.³ This episode serves to remind that market demand is the real indicator of consumer interest.

Once the basic decision was taken to focus on 3.5-inch bamboo treadle pumps, a number of modifications were made to make the treadle pump suitable for local use. The check valve was adjusted, so that it could be changed easily from outside the barrel. Also, a metal bar was attached to the treadle pump to make it easier to carry. The pipe was extended, so that it fitted into the narrow bamboo strainers most common in northern West Bengal. Finally, the barrel was extended to 45 cm, so as to increase the discharge.

Five seasons of treadle pump promotion

Promotion of the treadle pumps started in the *rabi* dry winter season, November 1995 to April 1996. This is the irrigation season

and demand was not expected to be significant in the other seasons. While designing the promotion campaign, a number of decisions were taken.

- A high-quality treadle pump would be promoted at a fixed non-subsidized price. The idea was to set a standard and create a reputation for the treadle pumps and avoid that the treadle pump market in this initial stage would be spoiled by spurious models.
- To safeguard the quality of the pump, a purchaser would receive a one-year warranty card and each pump would have a punch plate with a unique number.
- This decision, i.e., the choice for a quality product, had strong implications for the manufacturing and marketing strategies. Quality production and quality control implied a centralized manufacturing facility. In other states some manufacturers were already in business, but an effort was also made to set up a manufacturer in northern West Bengal itself.
- In its turn, the central manufacture of the pump implied a long single marketing chain from a limited number of central manufacturers to a large number of remote rural customers.

The first season

In the first season of treadle pump promotion, the strategy consciously strongly relied on direct marketing through local well developers or local mechanics. The local mechanics were trained in treadle pump installation and maintenance and were offered a margin of Rs 25 on each treadle

³ Although in the first year 5-inch treadle pumps were half-heartedly also promoted, they were withdrawn soon after for a lack of demand. They looked good, but were unwieldy and expensive.

pump they installed. They would lift the pumps from local dealers, who were given a similar margin. The price of the treadle pump to the consumer, including these margins, was very low at Rs 250. With the cost of a bamboo well ranging between Rs 150–500, a farmer could irrigate 0.2 ha of land with an investment of less than Rs 1000. As awareness about the product was getting less attention, in the first ‘trial’ season, emphasis was put more on promotion and less on setting up a full supply chain.

The direct marketing effort was supported by two marketing teams, each consisting of three promoters, whose task was to build up local mechanic networks in the blocks in which the marketing efforts were concentrated. Each team further undertook general promotion through demonstrations in rural markets on main market days. A variety of other promotion tools were used, such as rickshaw announcements and the screening of a video-drama, revolving around a treadle pump.

The trial promotion concentrated on the 8 ‘most promising’ blocks in 3 districts. They were chosen because they were areas with shallow groundwater, where irrigated vegetable and winter rice cultivation had already begun. The results of the first year were better than expected with 903 treadle pumps sold. A shortage of diesel at the end of the irrigation season boosted the first year’s sales campaign.

The IDE, the NGO responsible for the promotion of the treadle pumps, played the role of main distributor as well, supplying the dealers and the local mechanics, thus positioning itself in the marketing chain. Efforts were started to build up local manufacturing capacity. The production of the treadle pumps required a pressing machine,

a shearing machine, electricity supply, and working capital. No manufacturer in northern West Bengal was found possessing all these assets and also interested in starting a manufacturing line. Instead connections were established with a Calcutta-based manufacturer, making high quality drinking water pumps for UNICEF (United Nations Children’s Fund) programmes.

The second season

In the second season (1996/97), promotion activities were intensified and expanded geographically to all 15 blocks, where there was demand for the treadle pump–bamboo well combination. The promotion strategy also shifted, with greater emphasis on the dealers in promotion and less on the local mechanics. The argument was that dealers were a safer bet than the local mechanics in building up and consolidating an independent retail network. The latter lacked working capital and were engaged in an array of other activities. The chosen dealers were in most cases, local hardware shops or fertilizer dealers in the village markets. The policy was to give each selected dealer the monopoly of his (usually twice weekly) market. In all, 63 dealers were identified. Simultaneously, efforts were made to identify local distributors. This turned out to be relatively difficult, but two distributors were identified, while the IDE continued to play the role of central stockist. It also emerged that the retail sector was very fragmented in northern West Bengal. There was no permanent link between dealers and distributors. Although the emphasis in promotion shifted to dealers, the network of local mechanics was expanded as well, *inter alia*, by training 209 local mechanics for 3 days. The selected

local mechanics were by preference those with whom the dealers had already established a working relationship. They were also requested to assess the demand prior to the promotion season in the villages where they were operating. On that basis an exciting turnover of 11 000 treadle pumps for the season was expected.

Prior to the second promotion season the sales prices was increased to Rs 375. This was in response to increased material costs and also to allow larger margins for the distributor (Rs 25), dealer, (Rs 35), and local mechanic (Rs 35). The Government of West Bengal was requested to waive sales tax, but this effort was buried in bureaucracy.

The second promotion season (winter 1996/97) got off to a reasonable start in November and December, though the predicted high turnover was not achieved. The promotion was again supported by market demonstrations, dealer boards, handbills distribution, village demonstrations, wall paintings, and video shows in the local Bengali language. Sales slowed down in the middle of the promotion season. Prompted by some treadle pump dealers, the Government of West Bengal announced that it might include the treadle pumps in the package of subsidized (50%) agricultural implements under the Integrated Cereal Development Project. Sales at the end of this season were 2400 branded pumps plus 1253 non-branded pumps. Whether this was a success or not, is a matter of opinion but it was clearly far less than expected on the basis of the pre-season market survey.

The subsidy scheme was withdrawn not long after it became effective, but the confusion that surrounded it (for potential customers and for dealers) had a serious effect on private sector promotion. The subsidy procedure itself was quite cumbersome. It concerned a screening of applicants and concession on delivery rather than an uncomplicated and neutral subsidy at the source. For the farmers it involved procuring and routing an application form through agricultural officers and local government officials. What is interesting though, is that in a relatively short period more than 3000 application forms were submitted by farmers, essentially to obtain a modest rebate of Rs 185 (50% of the price of the treadle pump) at a considerable transaction cost. This speaks of a culture in which subsidies are an important delivery mechanism.⁴ In all, 920 pumps were sold at a subsidized price.

The third season

The third promotion season consolidated the strategy of the previous year with some minor changes. There was even less emphasis on local mechanics as a sales force. The fixed margin for the local mechanic was dropped—if he landed the deal, it was for him to negotiate the price with the dealer. Rather than dealers or local mechanics the 15 marketing assistants engaged by the IDE became anchor points in the sales promotion.

The price of the treadle pump was also adjusted from Rs 375 to Rs 390. The promotion activities now also expanded to

⁴ Subsidies generate high interest not only from farmer-customers, but equally from dealers and manufacturers because of the scope of high volume sales they offer. Intriguingly the first move by many erstwhile treadle pump dealers in the area was to persuade local governments to include treadle pumps in subsidized programmes.

the entire vegetable and dry season rice belt of northern West Bengal. Within the area, high potential villages (high groundwater tables and experience with vegetable production) were singled out. Again, prior to the actual promotion season much attention was paid to familiarizing local mechanics with the treadle pumps and a total of 439 local mechanics were trained. There was a complete revamp of the dealer network prior to the season. The number of distributors increased from 3 to 7, while the IDE continued to be the link between the manufacturer (whom they subjected to quality control) and the distributor–dealer network (who were expected to sell the branded pumps). Of the 63 dealer points earlier, only 33 were retained and 61 new dealers were approached. Non-performing dealers and those actively pursuing government or Panchayat subsidization were dropped. The one-market-one-dealer strategy was maintained to attract potential dealers with the promise of a temporary monopoly and encourage them to try harder to promote the treadle pump, which after all, was just one product out of a large range of items for sale.

It became more and more apparent that the dealer network, as it existed in northern West Bengal, had its limitations. There were several areas without fertilizer or hardware shops. The market, in other words, did not cover all areas. Another major limitation is the prevalent system of sale-on-credit coupled with the modest working capital most dealers had. As a consequence each dealer has a limited clientele (often 80–100 customers) to which he will sell on credit or on whose recommendation he will accept new customers. Non-credit sales are limited, particularly at the start of a cultivation season.

To stimulate sales, the IDE, therefore, decided to relax its earlier insistence on payment by cash and instead advanced credit-on-sales to the distributors and dealers. This amounted to approximately 2 00 000 rupees or close to 20% of the total turnover for that season. A second change was that at some places the one-dealer-one-market policy was removed, as it was unnecessarily limiting the number of outlets.

In spite of the credit advance, the increased familiarity, and the revamped and expanded dealer network, treadle pump sales in this third season were not significantly different from those of the previous season. The sale of branded treadle pumps amounted to 2584, and an estimated 500 non-branded pumps were sold, a decrease from previous years. This was achieved at the price of an intensive promotion campaign, consisting of more than 1600 promotional events (market demonstrations, village demonstrations, and short campaigns), including 67 widely-attended video shows.

While searching for explanations, it appeared that the plummeted potato and jute prices in the summer of 1997 were one reason. The low prices left farmers with very little capital to invest in irrigated winter crops which also require high costs on agro-inputs. A second possible external factor was the early rains in 1998, making irrigation and hence the purchase of a treadle pump in the region less important. But other explanations should be sought in the promotion campaign itself—the newness of most dealers and the tendency of the marketing assistants to generate direct sales rather than supporting the promotion through dealers and local mechanics. This turned marketing assistants into salesmen chasing targets and brought the number of

across-the-counter sales by dealers, down to 35%.

The fourth season

There was considerable soul-searching at the start of the fourth promotion season. One outcome of this was the development of a strategy to make several promotional activities more effective. This was done, *inter alia*, by selling coupons at demonstration events, which entitled the prospective buyer to a discount. It was hoped that the interest generated during those events could be translated into product sales rather than product awareness. Also, the importance of addressing women farmers in the treadle pump campaign was stressed, particularly by organizing special demonstrations for village women. Furthermore, the promotion activities were routed and planned with greater involvement of the dealers than in the past. Marketing assistants were instructed to facilitate the development of the supply chain, rather than play a promotional role, and were also better supervised in this respect. Counter sales were to go up to 50%. A stronger role was expected of the distributors in stocking the dealers.

Sales in the fourth promotion season went up from the previous year, but not by a quantum leap. The season resulted in sales of 3000 branded pumps and 500 non-branded pumps. This was achieved again, with an intensive promotion campaign, concentrating on village and market demonstrations, comparable to those of the previous season. The innovative coupon system, whereby a farmer would buy a coupon, entitling him to a discount larger than the price of the coupon initially, generated a lot of interest. However, it was disappointing to note that the initial

interest did not translate into sales and many coupons went unused.

It must be mentioned that the slightly increased sales were achieved in a second difficult marketing season. In February and March the bottom dropped out of the vegetable prices. The reason was persistent clear weather, which limited pest damage and caused a glut.

The dealer network had stabilized and in contrast to the previous season, across-the-counter sales accounted for 80% of the turnover. Moreover, the dealer network consolidated, with only minor substitution of non-performing outlet points. It also became clear that sales would be in the 3000–4000 per annum range and that the high annual sales, that were predicted once, were not attainable with the current effort and strategy.

The fifth season

In the fifth season (1999/2000) a withdrawal strategy was initiated. It consisted of a shift from dynamic promotion (such as village demonstrations and market demonstrations) to static promotion (flyers, wall paintings) and the use of mass media. This reduced the pressure on staff time and the number of full-time marketing managers and assistants was reduced by a third (from 12 to 8). In one of the most established areas (Chilkir Haat) dynamic promotion was by way of experiment, stopped completely. Sales in these areas dropped from the previous year, but not dramatically (only 15%) and a safe platform seemed to have been reached.

The IDE also gradually withdrew from the marketing chain. Thus far, the IDE had served as the link between treadle pump manufacturers and distributors and also

provided trade credit to the system. In this season a start was made with establishing links directly between the manufacturer and the distributors of pumps.

Overall sales of branded pumps for the season stabilized at a slightly lower level than in the previous season with a turnover of 2500. Non-branded pump sales, in this case from new local workshops, were 200.

The rural marketing approach: an analysis

Was the rural marketing approach to irrigation development successful? Could the market deliver? In five seasons, some 11 500 treadle pumps were purchased. Detailed monitoring of selected treadle pumps suggested that they served an area of 0.18–0.23 ha in the winter and spring season. The campaign hence yielded 2300 ha under irrigation, most of this under high-value vegetable cultivation by small farmers. A socio-economic survey was undertaken after the first promotion season and revealed that 64% of treadle pump buyers were marginal farmers (land holdings less than 1 ha) and 27%, small farmers. There were also a few landless treadle pump buyers. The bias is clearly towards the small rather than marginal farmers and is not surprising for a population of early adopters. Due to its labour-intensive nature however, the treadle pump is largely self-selecting. The survey also indicated that almost all treadle pump owners were predominantly dependent on an agricultural income and that the possibility of irrigated agriculture resulted in measurable income gains. Female members of the family were increasingly enlisted into the family enterprise once the pump was bought. In 48% of cases

treadle pumps were also used to obtain drinking water. In the rest of the cases, the well was too far, there were better alternatives or there were cultural taboos (pumping with the feet). Monitoring established that water from the treadle pump (due to the absence of a platform and the practice of priming with contaminated water) met WHO (World Health Organization) standards in only 30% of cases. However, opening courtyard wells, which are the most common source of drinking water in rural northern West Bengal, fell short of the WHO standards by an even larger measure.

The cost of promoting this new technology over 5 seasons worked out to Rs 1100 per treadle pump. The typical cost to a farmer for the treadle pump plus the installation of a bamboo strainer well was Rs 900. The cost per hectare irrigated was then Rs 10 000.

Though the cost of promotion forms a very large portion of total expenditure, the total cost is still short of the normative ceilings that have been established for irrigation development. Comparison with a number of public sector minor irrigation development programmes that were simultaneously implemented in the same region will illustrate this more clearly. In programmes that developed hand tube wells, shallow tube wells, and small-scale river lift systems, the cost per area irrigated was, respectively, Rs 24 000; Rs 7 600, and Rs 60 000. These do not include the hidden cost of the government staff responsible for the programme's implementation.

So, on these grounds, the marketing approach was successful. It helped small and marginal farmers develop an area under demand-based irrigation at very reasonable costs. Moreover, with the treadle pump

programme, a system was established that would perpetuate, albeit with lesser intensity, even when the promotion would no longer be funded.

The promotion campaign

The marketing approach may have been successful, but, in retrospect, can the same be said for the design of the promotion campaign?⁵ Since documented experience with rural marketing is scarce, it is useful to take a closer look at the treadle pump promotion programme, including product choices, and marketing choices.

First, the rural marketing campaign exposed a dimension of rural underdevelopment that is not always obvious. The marketing system is weak—there is little trade capital flowing around, and links between suppliers and dealers are inarticulate. In such a system, transactions, particularly where they involve credit advances, are costly and will not come about easily. The rural private sector, as it exists in northern West Bengal, is weak. Where people are poor, the domestic private sector is equally poor.

Given this weakness, how well conceived was the adopted strategy? The question is particularly relevant, since projected sales were substantially higher than actual sales. The high expectations were based on the popularity of the treadle pump in adjoining districts in Bangladesh and confirmed in the marketing survey when the campaign begun. The large response to the subsidy package in 1997 also suggests a much higher latent demand.

The strategy had the following characteristics.

- It aimed to introduce a high quality product to a poor clientele, while trying to maintain a fixed and reasonable price.
- It worked with a long retail chain, consisting of Kolkata-based manufacturers, distributors, local dealers, local mechanics, where no such chain had existed earlier.
- The IDE, had to more or less insert itself into this long chain and occupy a commanding position in it, since it was responsible for quality control at the manufacturer's end; the licensing of local dealers and local mechanics; and providing trade credit.
- Though IDE did not finance the product, it subsidized an extremely intensive promotion campaign whose costs exceeded the treadle pump turnover.

This long retail chain was justified by the desire to guarantee quality. It aimed at approaching a new market with an assured product and building up a solid reputation. It led to the branding of the product, emphasis on quality control, and a warranty system, which was extraordinary in rural West Bengal. However, the emphasis on quality, meant that the manufacturer could not be a local one. This in turn, limited local spin-off, which had an effect on research and development and product innovation. Both could not develop into spontaneous processes, driven by customer feedback, and, instead, became a complementary service provided by the IDE.

A second drawback of having distant manufacturers was that they did not take

⁵ In hindsight, one may speculate that a less costly campaign might have had a similar promotion effect, but the discussion in this section is on the structure of the marketing campaign rather than the cost of the various components.

interest in promoting demand or even sustaining a supply to distributors. For the manufacturer, the treadle pump was just one product of many. Such manufacturers usually produce on demand and do not sell a product or even large stocks on credit. Nevertheless, 2 manufacturers established themselves as treadle pump producers, supplying to the entire state (not just the 3 districts), and invested in maintaining trade relations. A third Kolkata-based manufacturer withdrew. Its main business had been the production of hand pumps in a UNICEF created environment of high quality control and public sector contracts. As long as the IDE played the role of a free intermediary between manufacturers and distributors, it was in business—though at a modest stage. It lost interest the moment it had to develop its own and more risky relations with local distributors.

It must be said that efforts were undertaken to find a manufacturer, closer to the northern West Bengal market, but they never materialized. There were no entrepreneurs with the resources and the conviction that this was a risk worth taking and neither was the industrial climate in the region suitable. However, the lack of candidates also had to do with the high quality requirements of the product. This excluded small producers, such as those in the border villages, who had been manufacturing the pump for a number of years. Experience showed, however, that small producers came back into the picture in the fourth and fifth promotion season. This suggests that if sales increase to a certain density such workshops may find their way

into the market on a small scale, producing a product of lower quality, but also at a lower cost.

The second crucial link in the supply chain was the local dealers. Undercapitalized and disorganized,⁶ their outreach had its limitations. After 5 seasons of experience, it was clear that a poor rural economy has an equally underdeveloped private sector which is, at best, a weak partner—mainly small autonomous traders with limited working capital—in promoting a new product. Added to that was the fact that for both, manufacturers and distributors/dealers, the pump was only one of a range of products and that too, with a modest margin, making it unlikely that they would actively promote it, whatever its value as a social good.

As a result, the IDE had to intervene and for the first few years, it occupied a central and indispensable role in the marketing chain. It also financed an intensive promotion campaign, with costs exceeding turnover. One wonders what the demand would have been had the promotion costs been discounted in the sales prices. However, with promotion costs fully subsidized, the campaign had to face the devil of distortion—no correlation between subsidized promotion and real demand. The most dramatic expression of this was the third promotion season, when the marketing assistants turned into ‘free’ salespersons. This brought down across-the-counter sales and had a serious impact on the sustainability of the entire effort. It was fortunately corrected. The challenge, however, is how to support the marketing chain, without taking over it.

⁶ Apparently in other more intensely developed parts of India the retail sector is much more organized, with local dealers acting as agents of a central wholesaler.

Having reached a certain level of market saturation, there were a number of ways forward. The first was to re-encourage diversity, by bringing in local workshops, with shorter chains and large innovation capacities. The second was to de-emphasize promotion, assuming that with 11 500 treadle pumps in place and 5 seasons of promotion, product awareness would be well established. This would reduce costs dramatically. Promotion efforts should concentrate on a restricted role in the distribution chain, probably still controlling the quality of the product, and take a margin of the cost for this role. This would make it easier for the promoter to withdraw from this service or hand it over to another party.

Finally, control over the dealer's network should be given up—the more dealers the better. The licensing and the monopolies in existence are not justified, as the total turnover and promotion effort of individual dealers is too small to justify their monopolies. Moreover, for dealers treadle pumps are only one out of a range of products and their survival does not depend on this single product.

Subsidies or promotion

The rural marketing campaign as described poses one final intriguing question—would subsidies not have achieved a larger turnover for the same amount of money? This was a point of discussion on a number of occasions, particularly when the Government of West Bengal indirectly funded the promotion campaign. The subsidy argument ran as follows.

If one had subsidized 50% of the price of every treadle pump, the amount of money now spent on promotion would have

paid for 45 000 treadle pumps. With this number it would have been easy to withdraw the subsidies, and the coverage would have been so dense that a service sector of mechanics and dealers would have developed that could perpetuate the efforts, it being obvious that the treadle pump has a demand even without a subsidy.

An interesting episode occurred in 1997, when subsidies on treadle pumps were announced briefly. In just a short period, 3000 requests for a 50% subsidy on treadle pumps were collected, at that time equivalent to a modest discount of Rs 185. To avail of the discount considerable transaction costs (Rs 50–60) had to be incurred by the applicants. Even then, the total number of applications was of the order of the total sales for the entire area, though the subsidy offer was only open in part of the area. This shows the undeniable appeal of subsidized items and a certain confidence in the public sector as deliverer.

There are a number of flaws in the subsidy argument though, which relate mainly to the way they are managed. The first is that when a product is new and the basics of its use are not well known, a subsidized environment has a tendency to discourage the building-up of basic local technical skills—the negative reception of the trial treadle pumps in the first season illustrates this danger. This is exactly what happened in northern West Bengal with subsidized seed drills, for which no local capacity to repair the otherwise useful implements was developed. Second, experience in northern West Bengal showed that subsidies attract entrepreneurs who may not be willing to act as dealers and distributors in a non-subsidized environment. This was obvious when the treadle pumps were first promoted

in the region. Several self-sought intermediaries directed their efforts at persuading local governments to buy and distribute treadle pumps from their development budget. Their niche was brokerage, not hardware sales. It was difficult to undo their efforts. A final flaw in the subsidy argument is that it underestimates the costs of administering the subsidy for the public sector. This may be substantial too and even more than the cost of engaging the private sector to promote a new product.

Even so, on the basis of the treadle pump promotion we think that subsidies should not be dismissed off-hand. There is scope for what Shah (1998) in a study on the diesel pump set programme in North Bihar has called 'smart subsidies'—subsidies at source, channelled through the private sector, avoiding bureaucratic and petty political selectiveness. Smart subsidies in North Bihar meant that rather than all the energy being spent on clearing complex procedures, the initiative lay with dealers. They identified customers who fitted the criteria, arranged the applications, thus filling a subsidized-sales quota. This model had the private sector in the driving seat and did not displace it with a non-permanent government delivery mechanism. Although it may be heresy to some, we argue that subsidies should not be automatically excluded as an option to promote investments in water infrastructure by poor water users or poor communities.

The larger point this chapter wants to make is that rather than putting all the faith in an imaginary effective market, there is need to understand what the market mechanism practically and physically really is, in a given area—the shops, the

dealers, and the wholesalers, undercapitalized or powerful, linked or disjointed.

References

- Global Water Partnership. 2000
Towards Water Security: Framework for Action to Achieve the Vision for Water in the 21st Century
The Hague: World Water Forum
- Heierli U. 2000
Poverty alleviation as a business: the market creation approach to development.
Bern: Swiss Agency for Development and Cooperation
- Jurrius I. 2000
Energy conservation in pumping water for irrigation in India
Department of Science, Technology and Society: Utrecht University
- Kundu N and G Soppe. 2002
Water resources assessment: Terai region of West Bengal
New Delhi: Jawahar Publishers
- Ministry of Water Resources. 1986
Groundwater development in India 1986
New Delhi: **Ministry of Water Resources**
- Nagar R K. 1999
IDC-SDC Foundation Study on Socio-Economic Impact of Treadle Pump Technology in Cooch Behar, North Bengal, India.
[Mimeograph]
New Delhi: International Development Enterprises
- Patel S M. 1988
Low-cost and quick-yielding measures for energy conservation in agricultural pumps
Pacific and Asian Journal of Energy

- Phansalkar S J. 1999
Mass marketing of KB pumps in East India during 1997–2000: an assessment
 Nagpur: Amol Management Consultants
- Ramaswamy U and Sengupta S. 1999
The treadle pump: changing lives of women and men
 New Delhi: International Development Enterprises
- Shah T. 1998
Elixir or opiate? An assessment of minor irrigation policies in North Bengal
 [Policy school working paper 3]
 Anand: The Policy School
- Shah T, Alam M, Kumar M D, Nagar R K, and Singh M. 2001
- Pedalling out of poverty: social impact of a manual irrigation technology in South Asia**
 [Research Report 45]
 Colombo: IWMI
- Sutherland D. 1999
Sustainable groundwater irrigation technology: guidelines of good practice based on experiences in Bangladesh and Pakistan
 Silsoe: Cranfield University
- Fraenkel P. 1997
Water-pumping devices: a handbook for users and choosers
 London: Intermediate Technology Publications

Index

A

adaptations required 17
agriculture sector, energy consumption in 2
aquifer composition at Haldibari site 45

C

check valve, removal of 11
conveyance losses, categories of 57
cooling system, change in 15

D

dealer network, limitations of 80
deep-set low speed diesel pump, efficiency improvements for 21
deep-set pumps 10
delivery sector
 constraints in engaging 73
 organization of 73
demonstrations, organization of 68
design with gravel packing 38
diesel consumption in pumps 2
diesel pump set modifications, conclusions on 16
diesel pump sets
 categories of 19
 improvement of 9
dug-well technology 51
dug-wells
 failure of 51
 rehabilitation of 51

E

electric pump sets, stagnation in 2
electricity subsidies, India 1
energy consumption in agriculture sector 2
engine speed, reduction of 13
engines, types of 20

F

filter design, methodology of 35
filter frames, types of 36
filter loss, calculation of 42

filter net 35
foot valve, removal of 11
footpump well resistance test data 47
fuel efficiency, improvement in 20
fuel-efficient pump sets, promotion of 67
fuel savings at national level 21
fuel-savings, importance of 9

G

groundwater exploitation, levels of 1
groundwater irrigation systems, conveyance losses in 57
groundwater technology 9

H

hammer head
 raising of 54
 shape of 53
hand pumps 23

I

IDE (International Development Enterprises), role of 78
improved and present pump sets, comparison between 17
improvements after washing 41
India
 electricity subsidies 1
 irrigation potential 1
 rainfall in 1
initial filter loss survey, results of 34
innovation dissemination, resistance to 67
irrigation potential, India 1

L

labour and funds, availability of 31
labour and pump, relationship between 31
lay-flat hoses, advantages of 65
lay-flat tubes 58
local dealers, limitations of outreach of 84
low-cost channels, test results of 61
low-lift farmer-operated irrigation technology 5
low-lift groundwater technology 8

M

manual water lifting devices, cost of 30
 manufacturers
 convincing of 70
 lack of 84
 market mechanism, need to understand 86
mistri cooperatives, establishment of 69
 modification, impact of 11
 multifilter point shallow tube wells 71

N

national level impacts 18

O

ownership/technology relationship 6

P

PDW (pump dug wells), cost of modifying 16
 polyethylene tubes 58
 potential impact, conclusions on 22
 promotion campaign, success of 83
 promotion efforts, modified pump sets 69
 promotion strategy, characteristics of 83
 pump dug wells (*see* PDW)
 pump fairs 72
 pump sets
 comparison between 24
 conclusions on the new design of 18
 improving the design of 16
 quality of 2
 pump speed, reduction of 14
 PVC tubes 59

R

rainfall in India 1
 rope and washer pumps 29
 rope-and-bucket pumps 23
 rural marketing approach 82

S

shallow tube well 33
 shallow tube well washing 40
 sieve analysis, sample of 45
 smart subsidies, scope for 86

socio-economic survey 82
 soil-cement channels 59
 advantages of 60
 disadvantages of 64
 technical aspects of 62
 stone chisel, use of 52
 stone hammer kit, costs of 55
 stone hammer method 55
 stone hammer technique 52
 subsidy argument, flaws in 85
 surface diesel pumps 9
 modifications of 10

T

technology, right choice of 6
 technology/ownership relationship 6
 telescoping, attempt at 51
 test data, analysis of 38
 treadle pumps 23
 designing the promotion campaign 77
 in West Bengal 75, 76
 introduction of the 75
 promotion of the 8, 77
 subsidies for 79
 treadle pump promotion
 fourth season 81
 fifth season 81
 first season 77
 second season 78
 third season 79
 tube well design, improvements in 33, 34
 tube wells, research on improving the performance of 33

W

washing tube wells, conclusions on 41
 water management, state of 1
 well washing, results of 50
 wells
 costs of 39, 46
 for foot pumps 39
 single-person ownership of 6
 types of 33
 West Bengal, treadle pumps in 75, 76
 World Bank Minor Irrigation Project 7
World Water Vision 5